

Compaq StorageWorks

HSG80 ACS Solution Software Version 8.6 for Compaq OpenVMS

Installation and Configuration Guide

First Edition (June 2001)
Part Number: AA-RH4BD-TE
Compaq Computer Corporation

© 2001 Compaq Computer Corporation.

Compaq, the Compaq logo, and StorageWorks Registered in U.S. Patent and Trademark Office.

Microsoft, MS-DOS, Windows, Windows NT, Windows 2000 are trademarks of Microsoft Corporation.

All other product names mentioned herein may be trademarks of their respective companies.

Confidential computer software. Valid license from Compaq required for possession, use or copying. Consistent with FAR 12.211 and 12.212, Commercial Computer Software, Computer Software Documentation, and Technical Data for Commercial Items are licensed to the U.S. Government under vendor's standard commercial license.

Compaq shall not be liable for technical or editorial errors or omissions contained herein. The information in this document is provided "as is" without warranty of any kind and is subject to change without notice. The warranties for Compaq products are set forth in the express limited warranty statements accompanying such products. Nothing herein should be construed as constituting an additional warranty.

Compaq service tool software, including associated documentation, is the property of and contains confidential technology of Compaq Computer Corporation. Service customer is hereby licensed to use the software only for activities directly relating to the delivery of, and only during the term of, the applicable services delivered by Compaq or its authorized service provider. Customer may not modify or reverse engineer, remove, or transfer the software or make the software or any resultant diagnosis or system management data available to other parties without Compaq's or its authorized service provider's consent. Upon termination of the services, customer will, at Compaq's or its service provider's option, destroy or return the software and associated documentation in its possession.

Printed in the U.S.A.

HSG80 ACS Solution Software Version 8.6 for Compaq OpenVMS
Installation and Configuration Guide
First Edition (June 2001)
Part Number: AA-RH4BD-TE

Contents

About this Guide

Text Conventions	xiv
Symbols in Text	xv
Symbols on Equipment	xv
Rack Stability	xvi
Installation and Setup of the CD-ROM	xvi
Configuration Flowchart	xvii
Getting Help	xx
Compaq Technical Support	xx
Compaq Website	xxi
Compaq Authorized Reseller	xxi

Chapter 1

Planning a Subsystem

Defining the Subsystems	1-2
Controller Designations A and B	1-2
Controller Designations “This Controller” and “Other Controller”	1-3
Failover Mode	1-5
Multiple-Bus Failover Mode	1-5
Selecting a Cache Mode	1-6
Read Caching	1-7
Read-Ahead Caching	1-7
Write-Back Caching	1-7
Write-Through Caching	1-7
Enabling Mirrored Caching	1-8
The Command Console LUN	1-8
Determining the Address of the CCL	1-9
Connections	1-9
Naming Connections	1-9

Numbers of Connections	1-10
Assigning Unit Numbers	1-11
Matching Units to Host Connections in Multiple-Bus Failover Mode	1-12
Assigning Unit Numbers Depending on SCSI_VERSION	1-13
Assigning Host Connection Offsets and Unit Numbers in SCSI-3 Mode	1-13
Assigning Host Connection Offsets and Unit Numbers in SCSI-2 Mode	1-13
Assigning Unit Identifiers	1-14
Using CLI to Specify Identifier for a Unit	1-14
Using SWCC to Specify LUN ID Alias for a Virtual Disk	1-15
Selective Storage Presentation	1-15
Restricting Host Access in Multiple-Bus Failover Mode	1-15
Enabln the Access Path of Selected Host Connections	1-16
Restricting Host Access by Offsets	1-17
Worldwide Names (Node IDs and Port IDs)	1-18
Restoring Worldwide Names (Node IDs)	1-19
Unit Worldwide Names (LUN IDs)	1-20

Chapter 2

Planning Storage

Where to Start	2-2
Configuration Rules	2-3
Device PTL Addressing Convention	2-3
Determining Storage Requirements	2-10
Choosing a Container Type	2-11
Creating a Storageset Profile	2-12
Storageset Planning Considerations	2-14
Stripeset Planning Considerations	2-14
Mirrorset Planning Considerations	2-16
RAIDset Planning Considerations	2-18
Striped Mirrorset Planning Considerations	2-20
Storageset Expansion Considerations	2-21
Partition Planning Considerations	2-22
Defining a Partition	2-22
Guidelines for Partitioning Storagesets and Disk Drives	2-23
Changing Characteristics through Switches	2-23
Enabling Switches	2-23
Changing Switches	2-24
Storageset and Partition Switches	2-24
RAIDset Switches	2-24
Mirrorset Switches	2-25
Partition Switches	2-25

Initialization Switches	2–25
Chunk Size	2–26
Increasing the Request Rate	2–26
Increasing Sequential Data Transfer Performance	2–27
Save Configuration	2–28
Destroy/Nodestroy	2–28
Geometry	2–28
Unit Switches	2–29
Storage Maps	2–29
Creating a Storage Map	2–29
Example Storage Map - Model 4310R Disk Enclosure	2–30
Example Storage Map - Model 4350R Disk Enclosure	2–32
Example Storage Map - Model 4314R Disk Enclosure	2–33
Example Storage Map - Model 4354R Disk Enclosure	2–36
Using the LOCATE Command to Find Devices	2–38

Chapter 3

Preparing the Host System

Enterprise Storage RAID Array Storage System Installation	3–1
Making a Physical Connection	3–5
Preparing to Install the Host Bus Adapter	3–5
Installing the Host Bus Adapter	3–5
Verifying/Installing Required Versions	3–5

Chapter 4

Installing and Configuring the HS-Series Agent

Why StorageWorks Command Console (SWCC)?	4–1
Installation and Configuration Overview	4–2
About the Network Connection for the Agent	4–3
Options for Running the Agent	4–4
Before Installing the Agent	4–5
Installing and Configuring the Agent	4–6
Reconfiguring the Agent	4–10
Removing the Agent	4–13

Chapter 5

Configuration Procedures

Establishing a Local Connection	5–2
Setting Up a Single Controller	5–3
Power On and Establish Communication	5–3
Cabling a Single Controller	5–3

Configuring a Single Controller Using CLI	5-4
Verify the Node ID and Check for Any Previous Connections	5-4
Configure Controller Settings	5-5
Restart the Controller	5-6
Set Time and Verify all Commands	5-7
Plug in the FC Cable and Verify Connections	5-8
Repeat Procedure for Each Host Adapter	5-9
Verify Installation	5-9
Setting Up a Controller Pair	5-9
Power Up and Establish Communication	5-9
Cabling a Controller Pair	5-10
Configuring a Controller Pair Using CLI	5-10
Configure Controller Settings	5-12
Restart the Controller	5-12
Set Time and Verify All Commands	5-13
Plug in the FC Cable and Verify Connections	5-14
Repeat Procedure for Each Host Adapter Connection	5-15
Verify Installation	5-15
Configuring Devices	5-16
Configuring a Striperset	5-16
Configuring a Mirrorset	5-16
Configuring a RAIDset	5-17
Configuring a Striped Mirrorset	5-18
Configuring a Single-Disk Unit (JBOD)	5-19
Configuring a Partition	5-19
Assigning Unit Numbers and Unit Qualifiers	5-20
Assigning a Unit Number to a Stageset	5-20
Assigning a Unit Number to a Single (JBOD) Disk	5-21
Assigning a Unit Number to a Partition	5-21
Assigning Unit Identifiers	5-21
Using CLI to Specify Identifier for a Unit	5-21
Using SWCC to Specify LUN ID Alias for a Virtual Disk	5-22
Preferring Units	5-22
Configuration Options	5-23
Changing the CLI Prompt	5-23
Mirroring cache	5-23
Adding Disk Drives	5-23
Adding a Disk Drive to the Spareset	5-23
Removing a Disk Drive from the Spareset	5-24
Enabling Autospare	5-24
Deleting a Stageset	5-25
Changing Switches for a Stageset or Device	5-25

Displaying the Current Switches	5–25
Changing RAIDset and Mirrorset Switches	5–26
Changing Device Switches	5–26
Changing Initialize Switches	5–26
Changing Unit Switches	5–26

Chapter 6

Verifying Storage Configuration from the Host

Chapter 7

Configuration Example Using CLI

CLI Configuration Example	7–4
-------------------------------------	-----

Chapter 8

Backing Up the Subsystem, Cloning Data for Backup, and Moving Storage Sets

Backing Up the Subsystem Configuration	8–1
Cloning Data for Backup	8–2
Moving Storage Sets	8–6

Appendix A

Subsystem Profile Templates

Storage Set Profile	A–2
Storage Map Template 1 for the BA370 Enclosure	A–3
Storage Map Template 2 for the second BA370 Enclosure	A–4
Storage Map Template 3 for the third BA370 Enclosure	A–5
Storage Map Template 4 for the Model 4214R Disk Enclosure	A–6
Storage Map Template 5 for the Model 4254 Disk Enclosure	A–7
Storage Map Template 6 for the Model 4310R Disk Enclosure	A–9
Storage Map Template 7 for the Model 4350R Disk Enclosure	A–11
Storage Map Template 8 for the Model 4314R Disk Enclosure	A–12
Storage Map Template 9 for the Model 4354R Disk Enclosure	A–14

Appendix B

Installing, Configuring, and Removing the Client

Why Install the Client?	B–1
Before You Install the Client	B–2
Installing the Client	B–2
Troubleshooting the Client Installation	B–3
Invalid Network Port Assignments	
During Installation	B–3

“There is no disk in the drive” Message	B-4
Adding the Storage Subsystem and its Host to the Navigation Tree	B-5
Removing the Command Console Client	B-7
Where to Find Additional Information	B-8
About the User Guide	B-8
About the Online Help	B-8

Glossary

Index

Figures

Figure 1	General configuration flowchart	xviii
Figure 2	Configuring storage with the CLI	xix
Figure 3	Configuring storage with SWCC	xx
Figure 1-1	Location of controllers and cache modules in a Model 2200 enclosure	1-2
Figure 1-2	Location of controllers and cache modules in a BA370 enclosure	1-3
Figure 1-3	“This controller” and “other controller” for the Model 2200 enclosure	1-4
Figure 1-4	“This controller” and “other controller” for the BA370 enclosure	1-4
Figure 1-5	Typical multiple-bus configuration	1-6
Figure 1-6	Mirrored caching	1-8
Figure 1-7	Connections in multiple-bus failover mode	1-11
Figure 1-8	Limiting host access in multiple-bus failover mode	1-16
Figure 1-9	Placement of the worldwide name label on the Model 2200 enclosure	1-19
Figure 1-10	Placement of the worldwide name label on the BA370 enclosure	1-20
Figure 2-1	PTL naming convention	2-4
Figure 2-2	PTL addressing in a configuration in a BA370 enclosure	2-4
Figure 2-3	PTL addressing in a single-bus configuration, six Model 4310R disk enclosures	2-6
Figure 2-4	PTL addressing in a dual-bus configuration, three Model 4350R disk enclosures	2-7
Figure 2-5	PTL addressing in a single-bus configuration, six Model 4314R disk enclosures	2-8
Figure 2-6	PTL addressing in a dual-bus configuration, three Model 4354R disk enclosures	2-9
Figure 2-7	Mapping a unit to physical disk drives	2-10
Figure 2-8	Container types	2-11
Figure 2-9	An example storageset profile	2-13
Figure 2-10	A 3-member RAID 0 stripeset (example 1)	2-14
Figure 2-11	A 3-member RAID 0 stripeset (example 2)	2-15
Figure 2-12	Mirrorsets maintain two copies of the same data	2-17
Figure 2-13	Mirrorset example 2	2-17
Figure 2-14	A 5-member RAIDset using parity	2-18
Figure 2-15	Striped mirrorset (example 1)	2-20
Figure 2-16	Striped mirrorset (example 2)	2-21

Figure 2–17	One example of a partitioned single-disk unit	2–22
Figure 2–18	Chunk size larger than the request size.	2–26
Figure 2–19	Model 4310R disk enclosure – example storage map	2–31
Figure 2–20	Model 4350R disk enclosure – example storage map	2–33
Figure 2–21	Model 4314R disk enclosure – example storage map	2–35
Figure 2–22	Model 4354R disk enclosure – example storage map	2–37
Figure 3–1	Dual-Bus Enterprise Storage RAID Array Storage System	3–3
Figure 3–2	Single-Bus Enterprise Storage RAID Array Storage System.	3–4
Figure 4–1	An example of a network connection	4–4
Figure 5–1	Maintenance port connection	5–2
Figure 5–2	Single controller cabling	5–4
Figure 5–3	Controller pair failover cabling.	5–10
Figure 7–1	Example storage map for the BA370 Enclosure.	7–2
Figure 7–2	Example system	7–3
Figure 7–3	Example virtual system layout from the hosts’ point of view	7–4
Figure 8–1	Steps the CLONE utility follows for duplicating unit members.	8–3
Figure B–1	Navigation window	B–5
Figure B–2	Navigation window showing storage host system “Atlanta”.	B–6
Figure B–3	Navigation window showing expanded “Atlanta” host icon	B–6

Tables

Table 1-1 Unit Assignments and SCSI_VERSION.....	1-14
Table 2-1 A Comparison of Container Types	2-12
Table 2-2 Example Chunk Sizes	2-27
Table 4-1 SWCC Features and Components	4-2
Table 4-2 Installation and Configuration Overview	4-2
Table 4-3 Minimum OpenVMS Host Requirements	4-5
Table 4-4 Information Needed to Configure Agent.....	4-11

About this Guide

This guide provides installation and configuration instructions and reference material for operation of the HSG80 ACS Solution Software Version 8.6 for Compaq OpenVMS.

Thank You for selecting a *Compaq StorageWorks*[™] RAID Array subsystem for your growing storage needs. StorageWorks RAID subsystems are designed to support the most popular computer platforms in the industry. The solution software that accompanies this kit enables the new storage subsystem to work effectively with your chosen platform.

Please fill out and return the Registration Card included in this kit. This information is used by Compaq to provide notification services to its customers. You can also register online at:

<http://www.compaq.com/products/registration>

This guide describes:

- Considerations while planning a configuration
- Configuration procedures

This book does not contain information about the operating environments to which the controller may be connected; nor does it contain detailed information about subsystem enclosures or their components. See the documentation that accompanied these peripherals for information about them.

Text Conventions

This document uses the following conventions:

Keys	Keys appear in boldface. A plus sign (+) between two keys indicates that they should be pressed simultaneously.
USER INPUT, COMMANDS	* User input and commands appear in this typeface and in uppercase.
<i>Menu Options, type of user input</i>	Menu options and the type of user input, such as <i>device-name</i> , appear in italics.
<i>FILENAMES</i>	* File names appear in uppercase italics.
Dialog Box Names	These elements appear in initial capital letters.
DIRECTORY NAMES, and DRIVE NAMES	* These elements appear in uppercase.
Enter	When you are instructed to enter information, type the information and press the Enter key.
<i>Script</i>	Script names appear in upper and lower case in <i>this typeface</i> .
<i>SWITCHES</i>	Elements designated as switches appear in uppercase italics.

* UNIX commands are case sensitive and will not appear in uppercase.

Symbols in Text

The symbols found in this guide have the following meanings:



WARNING: Text set off in this manner indicates that failure to follow directions in the warning could result in bodily harm or loss of life.



CAUTION: Text set off in this manner indicates that failure to follow directions could result in damage to equipment or loss of information.

IMPORTANT: Text set off in this manner presents clarifying information or specific instructions.

Symbols on Equipment



Any surface or area of the equipment marked with these symbols indicates the presence of electrical shock hazards. Enclosed area contains no operator serviceable parts.

WARNING: To reduce the risk of injury from electrical shock hazards, do not open this enclosure.



Any RJ-45 receptacle marked with these symbols indicates a Network Interface Connection.

WARNING: To reduce the risk of electrical shock, fire, or damage to the equipment, do not plug telephone or telecommunications connectors into this receptacle.



Any surface or area of the equipment marked with these symbols indicates the presence of a hot surface or hot component. If this surface is contacted, the potential for injury exists.

WARNING: To reduce the risk of injury from a hot component, allow the surface to cool before working with it.



Power Supplies or Systems marked with these symbols indicate that the equipment is supplied by multiple sources of power.
WARNING: To reduce the risk of injury from electrical shock, remove all power cords to completely disconnect power from the system.



Any product or assembly marked with these symbols indicates that the component exceeds the recommended weight for one individual to handle safely.
WARNING: To reduce the risk of personal injury or damage to the equipment, observe local occupational health and safety requirements and guidelines for manual material handling.

Rack Stability



WARNING: To reduce the risk of personal injury or damage to the equipment, be sure that:

- The leveling jacks are extended to the floor.
 - The full weight of the rack rests on the leveling jacks.
 - The stabilizing feet are attached to the rack if it is a single rack installation.
 - The racks are coupled together in multiple rack installations.
 - A rack may become unstable if more than one component is extended for any reason. Extend only one component at a time.
-

Installation and Setup of the CD-ROM

Contents of CD-ROM:

- Solution Software
- Storage Works Command Console (SWCC) Agent and Client software
- Documentation

NOTE: Refer to the platform-specific release notes for detailed solution kit contents and release-specific information.

Configuration Flowchart

A three-part flowchart is shown on the following pages. Refer to these charts while configuring a new storage subsystem:

- Figure 1 on page xviii shows the start of the configuration process.
- Figure 2 on page xix shows how to configure storage with the command line interpreter (CLI), which is the low-level interface to the controller.
- Figure 3 on page xx shows how to configure storage using StorageWorks Command Console (SWCC), which is the graphical user interface to the controller.

All references in the flowcharts pertain to pages in this guide, unless otherwise indicated.

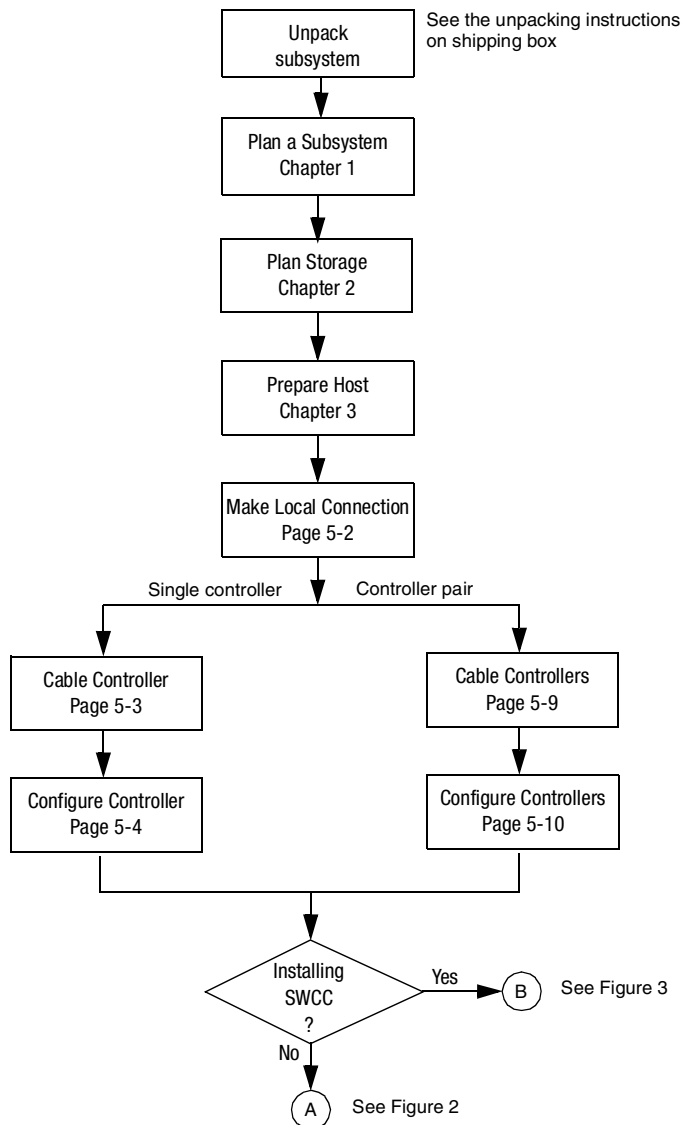

Figure 1. General configuration flowchart

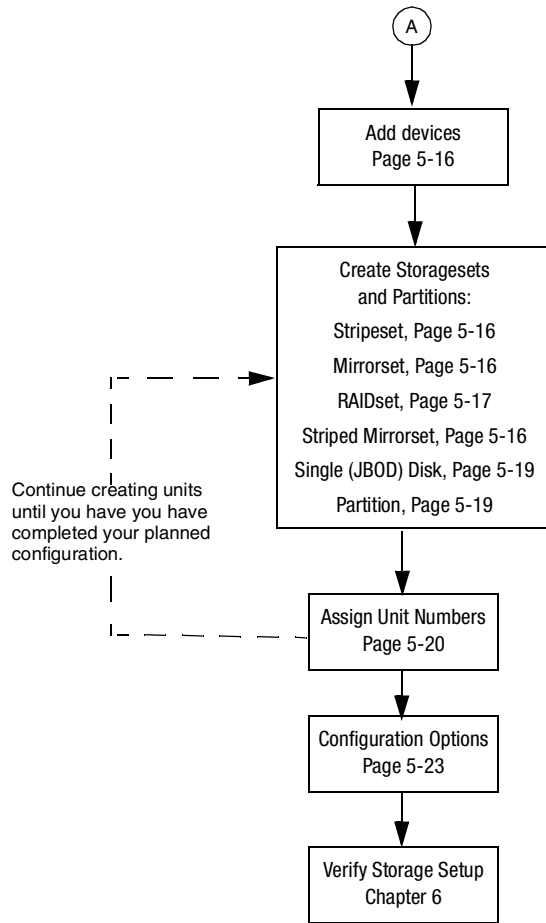

Figure 2. Configuring storage with the CLI

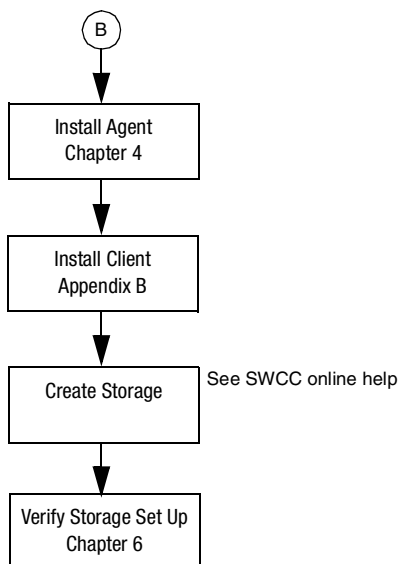

Figure 3. Configuring storage with SWCC

Getting Help

If you have a problem and have exhausted the information in this guide, you can receive further information and other help in the following locations.

Compaq Technical Support

A technical support specialist can help diagnose the problem or guide you to the next step in the warranty process.

In North America, call the Compaq Technical Phone Support Center at 1-800-OK-COMPAQ. This service is available 24 hours a day, 7 days a week.

NOTE: For continuous quality improvement, calls may be recorded or monitored.

Outside North America, call the nearest Compaq Technical Support Phone Center. Telephone numbers for worldwide Technical Support Centers are listed on the Compaq website. Access the Compaq website:

<http://www.compaq.com>

Be sure to have the following information available before you call Compaq:

- Technical support registration number (if applicable)
- Product serial numbers
- Product model names and numbers
- Applicable error messages
- Add-on boards or hardware
- Third-party hardware or software
- Operating system type and revision level
- Detailed, specific questions

Compaq Website

The Compaq website has latest information on this product as well as the latest drivers. Access the Compaq website at:

<http://www.compaq.com/storage>

Compaq Authorized Reseller

For the name of your nearest Compaq Authorized Reseller:

- In the United States, call 1-800-345-1518.
- In Canada, call 1-800-263-5868.
- Elsewhere, see the Compaq website for locations and telephone numbers.

Chapter 1

Planning a Subsystem

This chapter provides information that helps you plan how to configure the subsystem. Refer to Chapter 2 when planning the types of storage containers you need.

IMPORTANT: This chapter frequently references the command line interface (CLI). For the complete syntax and descriptions of the CLI commands, see the *Compaq StorageWorks HSG80 Array Controller ACS Version 8.6 CLI Reference Guide*.

The following information is included in this chapter:

- “Defining the Subsystems,” page 1–2
- “Failover Mode,” page 1–5
- “Selecting a Cache Mode,” page 1–6
- “Enabling Mirrored Caching,” page 1–8
- “The Command Console LUN,” page 1–8
- “Connections,” page 1–9
- “Assigning Unit Numbers,” page 1–11
- “Assigning Unit Identifiers,” page 1–14
- “Worldwide Names (Node IDs and Port IDs),” page 1–18

IMPORTANT: DILX should be run for ten minutes on all units to delete the 8 MB EISA partition. Refer to *Compaq StorageWorks HSG80 Array Controller ACS Version 8.6 CLI Reference Guide* for details.

Defining the Subsystems

This section describes the terms *this controller* and *other controller*. It also presents graphics of the Model 2200 and BA370 enclosures.

NOTE: The HSG80 controller uses the BA370 or Model 2200 enclosure.

Controller Designations A and B

The terms A, B, “this controller,” and “other controller,” respectively are used to distinguish one controller from another in a two-controller (also called dual-redundant) subsystem. These terms are described more thoroughly in the following sections.

Controllers and cache modules are designated either A or B depending on their location in the enclosure, as shown in Figure 1-1 for the Model 2200 enclosure and as shown in Figure 1-2 for the BA370 enclosure.

Model 2200 Enclosure

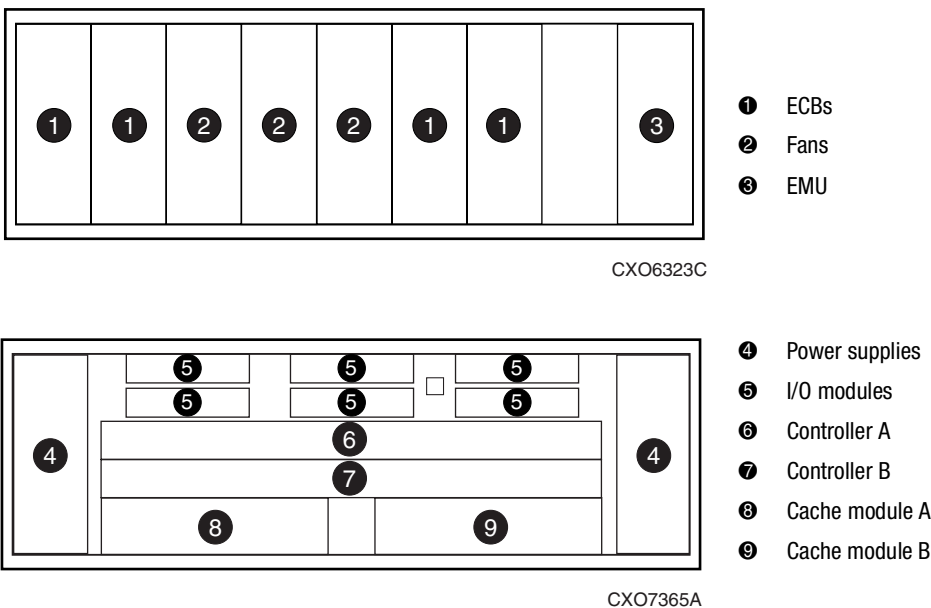

Figure 1-1. Location of controllers and cache modules in a Model 2200 enclosure

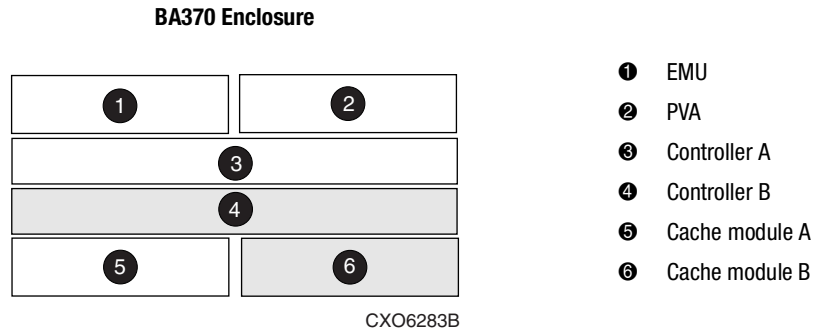

Figure 1-2. Location of controllers and cache modules in a BA370 enclosure

Controller Designations “This Controller” and “Other Controller”

Some CLI commands use the terms “this” and “other” to identify one controller or the other in a dual-redundant pair. These designations are a shortened form of “this controller” and “other controller.” These terms are defined as follows:

- **“this controller”**—the controller that is the focus of the CLI session. “This controller” is the controller to which the maintenance terminal is attached and through which the CLI commands are being entered. “This controller” can be shortened to “this” in CLI commands.
- **“other controller”**—the controller that is not the focus of the CLI session and through which CLI commands are not being entered. “Other controller” can be shortened to “other” in CLI commands.

Figure 1-3 shows the relationship between “this controller” and “other controller” in a Model 2200 enclosure, and Figure 1-4 shows the same relationship in a BA370 enclosure.

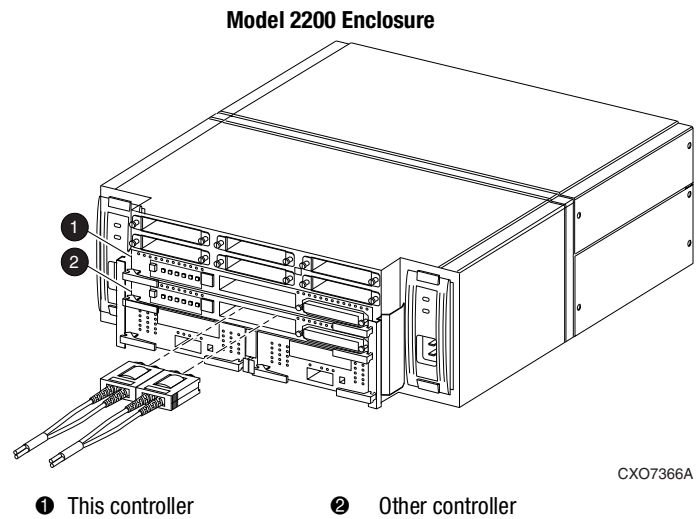

Figure 1-3. “This controller” and “other controller” for the Model 2200 enclosure

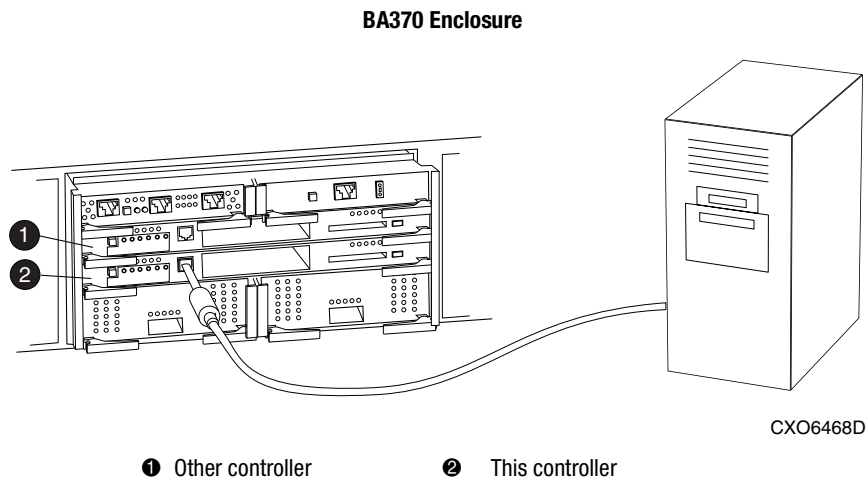

Figure 1-4. “This controller” and “other controller” for the BA370 enclosure

Failover Mode

Failover is a way to keep the storage array available to the host if one of the controllers becomes unresponsive. A controller can become unresponsive because of a hardware failure, such as a controller. Failover keeps the storage array available to the hosts by allowing the surviving controller to take over total control of the subsystem.

Multiple-Bus Failover Mode

Multiple-bus failover mode has the following characteristics:

- Host controls the failover process by moving the unit(s) from one controller to another
- All units (0 through 199) are visible at all host ports
- Each host has two or more paths to the units

All hosts must have operating system software that supports multiple-bus failover mode. With this software, the host sees the same units visible through two (or more) paths. When one path fails, the host can issue commands to move the units from one path to another. A typical multiple-bus failover configuration is shown in Figure 1-5.

In multiple-bus failover mode, you can specify which units are normally serviced by a specific controller of a controller pair. This process is called preferring or preferment. Units can be preferred to one controller or the other by the *PREFERRED_PATH* switch of the *ADD UNIT* (or *SET unit*) command. For example, use the following command to prefer unit D101 to “this controller”:

```
SET D101 PREFERRED_PATH=THIS_CONTROLLER
```

NOTE: This is an initial preference, which can be overridden by the hosts.

Keep the following points in mind when configuring controllers for multiple-bus failover:

- Multiple-bus failover can compensate for a failure in any of the following:
 - Controller
 - Switch or hub
 - Fibre Channel link
 - Host Fibre Channel adapter
- A host can redistribute the I/O load between the controllers
- All hosts must have operating system software that supports multiple-bus failover mode

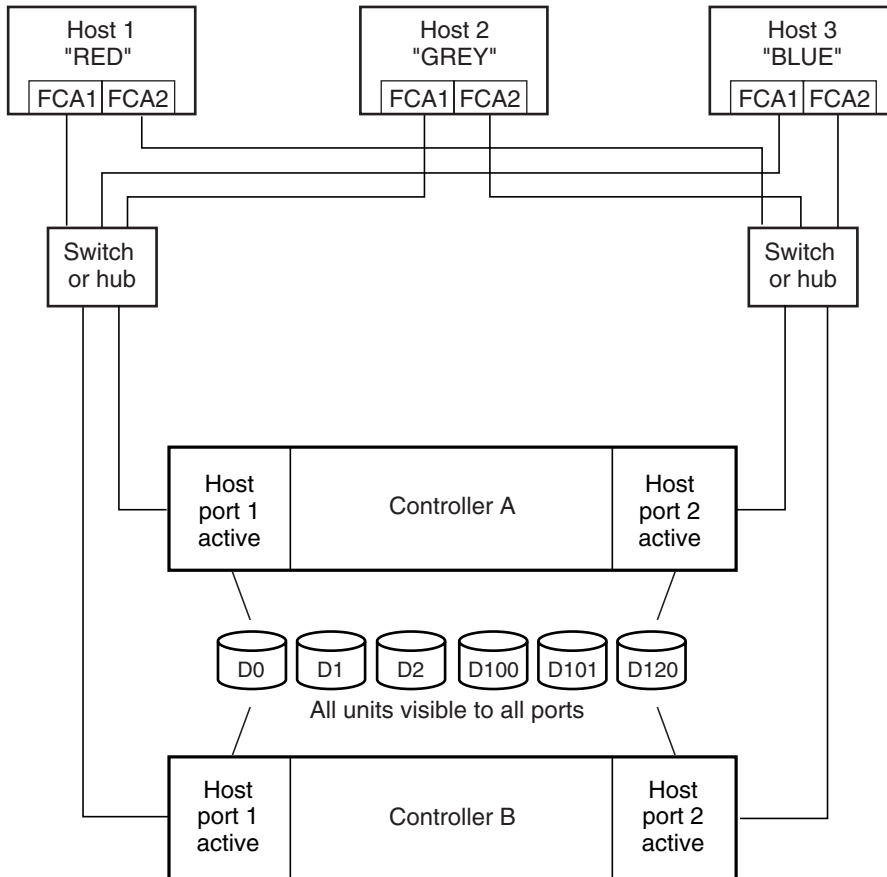

NOTE: FCA = Fibre Channel Adapter

CXO7094B

Figure 1-5. Typical multiple-bus configuration

Selecting a Cache Mode

The cache module supports read, read-ahead, write-through, and write-back caching techniques. The cache technique is selected separately for each unit. For example, you can enable only read and write-through caching for some units while enabling only write-back caching for other units.

Read Caching

When the controller receives a read request from the host, it reads the data from the disk drives, delivers it to the host, and stores the data in its cache module. Subsequent reads for the same data will take the data from cache rather than accessing the data from the disks. This process is called read caching.

Read caching can improve response time to many of the host's read requests. By default, read caching is enabled for all units.

Read-Ahead Caching

During read-ahead caching, the controller anticipates subsequent read requests and begins to prefetch the next blocks of data from the disks as it sends the requested read data to the host. This is a parallel action. The controller notifies the host of the read completion, and subsequent sequential read requests are satisfied from the cache memory. By default, read-ahead caching is enabled for all units.

Write-Back Caching

Write-back caching improves the subsystem's response time to write requests by allowing the controller to declare the write operation complete as soon as the data reaches cache memory. The controller performs the slower operation of writing the data to the disk drives at a later time.

By default, write-back caching is enabled for all units, but only if there is a backup power source for the cache modules (either batteries or an uninterruptable power supply).

Write-Through Caching

Write-through caching is enabled when write-back caching is disabled. When the controller receives a write request from the host, it places the data in its cache module, writes the data to the disk drives, then notifies the host when the write operation is complete. This process is called write-through caching because the data actually passes through—and is stored in—the cache memory on its way to the disk drives.

Enabling Mirrored Caching

In mirrored caching, half of each controller's cache mirrors the companion controller's cache, as shown in Figure 1-6.

The total memory available for cached data is reduced by half, but the level of protection is greater.

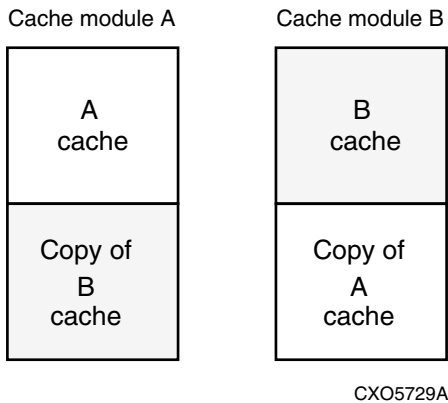

Figure 1-6. Mirrored caching

Before enabling mirrored caching, make sure the following conditions are met:

- Both controllers support the same size cache.
- Diagnostics indicate that both caches are good.
- No unit errors are outstanding, for example, lost data or data that cannot be written to devices.
- Both controllers are started and configured in failover mode.

The Command Console LUN

StorageWorks Command Console (SWCC) software communicates with the HSG80 controllers through an existing storage unit, or logical unit number (LUN). The dedicated LUN that SWCC uses is called the Command Console LUN (CCL). CCL serves as the communication device for the HS-Series Agent and identifies itself to the host by a unique identification string. By default, a CCL device is enabled within the HSG80 controller on host port 1. The HSG80 uses SCSI-3.

The CCL does the following:

IMPORTANT: OpenVMS requires the controllers be set to SCSI-3 mode.

- Allows the RAID Array to be recognized by the host as soon as it is attached to the SCSI bus and configured into the operating system.
- Serves as a communications device for the HS-Series Agent. The CCL identifies itself to the host by a unique identification string. This string, *HSG80CCL*, is returned in response to the inquiry command.

In dual-redundant controller configurations, the commands described in the following sections alter the setting of the CCL on both controllers. The CCL is enabled only on host port 1. At least one storage device of any type must be configured on host port 2 before installing the Agent on a host connected to host port 2.

Select a storageset that you plan to configure and that is not likely to change. This storageset can be used by the Agent to communicate with the RAID Array. Deleting this storageset (LUN) later breaks the connection between the Agent and the RAID Array.

Determining the Address of the CCL

CCL is enabled by default. Its address can be determined by entering the following CLI command:

```
HSG80 > SHOW THIS_CONTROLLER
```

Connections

The term “connection” applies to every path between a Fibre Channel adapter in a host computer and an active host port on a controller.

NOTE: In ACS V8.6 the maximum number of supported connections is 96.

Naming Connections

Compaq highly recommends that you assign names to connections that have meaning in the context of your particular configuration. One system that works well is to name each connection after its host, its adapter, its controller, and its controller host port, as follows:

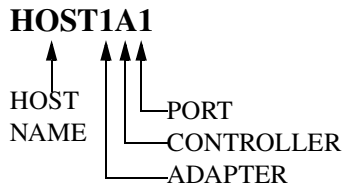

Examples:

A connection from the first adapter in the host named RED that goes to port 1 of controller A would be called RED1A1.

A connection from the third adapter in host GREEN that goes to port 2 of controller B would be called GREEN3B2.

NOTE: Connection names can have a maximum of 9 characters.

Numbers of Connections

The number of connections resulting from cabling one adapter into a switch or hub depends on failover mode and how many links the configuration has:

- If a controller pair is in multiple-bus failover mode, each adapter has two connections, as shown in Figure 1-7.

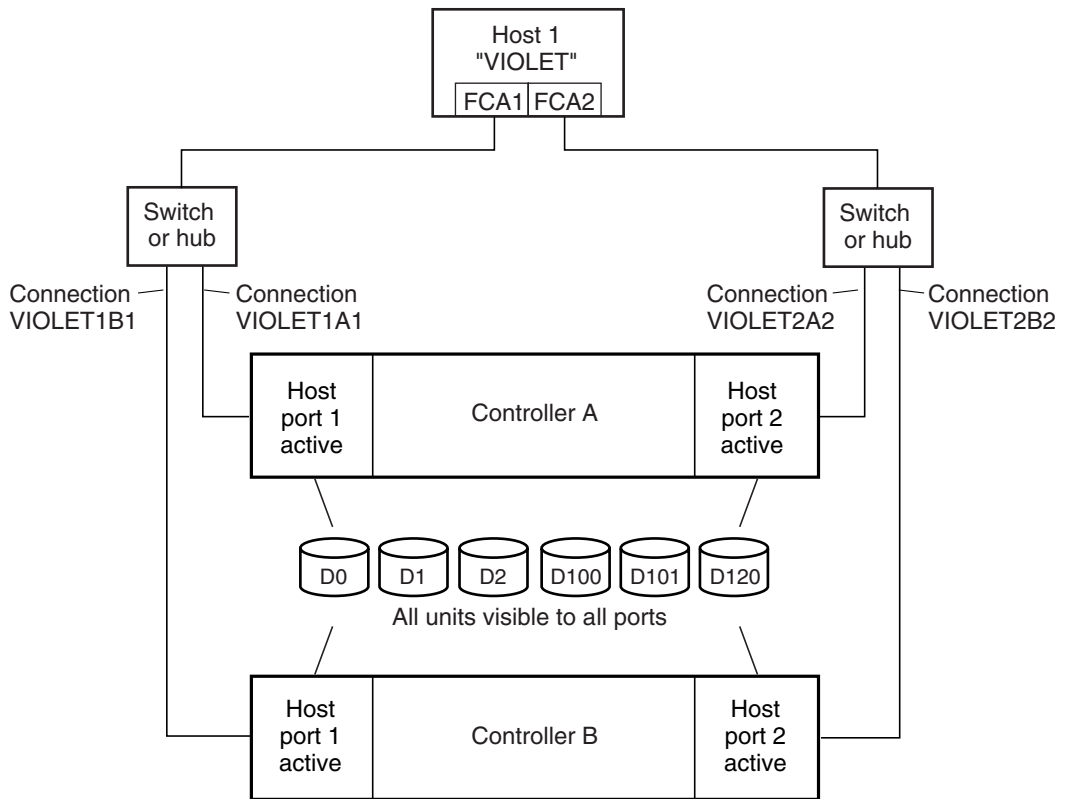

NOTE: FCA = Fibre Channel Adapter

CXO7080B

Figure 1-7. Connections in multiple-bus failover mode

Assigning Unit Numbers

The controller keeps track of the unit with the unit number. The unit number can be from 0–199 prefixed by a D, which stands for disk drive. A unit can be presented as different LUNs to different connections. The interaction of a unit and a connection is determined by several factors:

- Failover mode of the controller pair
- The *ENABLE_ACCESS_PATH* and *PREFERRED_PATH* switches in the ADD UNIT (or SET *unit*) commands

- The *UNIT_OFFSET* switch in the ADD CONNECTIONS (or SET *connections*) commands
- The controller port to which the connection is attached
- The *SCSI_VERSION* switch of the SET *THIS_CONTROLLER/OTHER_CONTROLLER* command

The considerations for assigning unit numbers are discussed in the following sections.

Matching Units to Host Connections in Multiple-Bus Failover Mode

In multiple-bus failover mode, the ADD UNIT command creates a unit for host connections to access. All unit numbers (0 through 199) are potentially visible on all four controller ports, but are accessible only to those host connections for which access path is enabled and which have offsets in the unit's range.

The LUN number a host connection assigns to a unit is a function of the *UNIT_OFFSET* switch of the ADD (or SET) CONNECTIONS command. The default offset is 0. The relationship of offset, LUN number, and unit number is shown in the following equation:

$$\text{LUN number} = \text{unit number} - \text{offset}$$

Where . . .

- LUN number is relative to the host (number the host sees the unit as)
- Unit number is relative to the controller (number the controller sees the unit as)

For example, unit D7 would be visible to a host connection with an offset of 0 as LUN 7 (unit number of 7 minus offset of 0). Unit D17 would be visible to a host connection with an offset of 10 as LUN 7 (unit number of 17 minus offset of 10). The unit would not be visible at all to a host connection with a unit offset of 18 or greater, because that offset is not within the units range (unit number of 17 minus offset of 18 is a negative number).

In addition, the access path to the host connection must be enabled for the connection to access the unit. This is done through the *ENABLE_ACCESS_PATH* switch of the ADD UNIT (or SET *unit*) command.

The *PREFERRED_PATH* switch of the ADD UNIT (or SET *unit*) command determines which controller of a dual-redundant pair initially accesses the unit. Initially, *PREFERRED_PATH* determines which controller presents the unit as Ready. The other controller presents the unit as Not Ready. Hosts can issue a SCSI Start Unit command to move the unit from one controller to the other.

Assigning Unit Numbers Depending on SCSI_VERSION

The SCSI_VERSION switch of the SET *THIS_CONTROLLER/OTHER_CONTROLLER* command determines how the CCL is presented. There are two choices: SCSI-2 and SCSI-3. The choice for SCSI_VERSION affects how certain unit numbers and certain host connection offsets interact.

NOTE: OpenVMS requires the controllers be set to SCSI-3 mode.

Assigning Host Connection Offsets and Unit Numbers in SCSI-3 Mode

If SCSI_VERSION is set to SCSI-3, the CCL is presented as LUN 0 to all connections. The CCL supersedes any other unit assignment. Therefore, in SCSI-3 mode, a unit that would normally be presented to a connection as LUN 0 is not visible to that connection at all.

The following methods are recommended for assigning host connection offsets and unit numbers in SCSI-3 mode:

- Offsets should be divisible by 10 (for consistency and simplicity).
- Unit numbers should not be assigned at connection offsets (to avoid being masked by the CCL at LUN 0).

For example, if a host connection has an offset of 20 and SCSI-3 mode is selected, the connection will see LUNs as follows:

LUN 0 - CCL
LUN 1 - unit 21
LUN 2 - unit 22, etc.

In this example, if a unit 20 is defined, it will be superseded by the CCL and invisible to the connection.

Assigning Host Connection Offsets and Unit Numbers in SCSI-2 Mode

Some operating systems expect or require a disk unit to be at LUN 0. In this case, it is necessary to specify SCSI-2 mode.

If *SCSI_VERSION* is set to SCSI-2 mode, the CCL floats, moving to the first available LUN location, depending on the configuration.

It is recommended to use the following conventions when assigning host connection offsets and unit numbers in SCSI-2 mode:

- Offsets should be divisible by 10 (for consistency and simplicity).
- Unit numbers should be assigned at connection offsets (so that every host connection has a unit presented at LUN 0).

Table 1-1 summarizes the recommendations for unit assignments based on the SCSI_VERSION switch.

SCSI_VERSION	Offset	Unit Assignment	What the connection sees LUN 0 as
SCSI-2	Divisible by 10	At offsets	Unit whose number matches offset
SCSI-3	Divisible by 10	Not at offsets	CCL

Assigning Unit Identifiers

One step is required when configuring storage units for specifying an identifier (or LUN ID alias) for each unit. A unique identifier is required for each unit (virtual disk). This identifier must be unique in the cluster.

This section gives two examples of setting an identifier for a previously created unit: one using CLI and one using SWCC. The CLI uses the older terms “identifier” and “unit”, while SWCC uses the terms “LUN ID alias” and “virtual disk”.

Identifier = LUN ID alias

Unit = virtual disk

Using CLI to Specify Identifier for a Unit

The command syntax for setting the identifier for a previously created unit (virtual disk) follows:

```
SET UNIT_NUMBER IDENTIFIER=NN
```

NOTE: It is strongly suggested that, for simplicity, the identifier match the unit number. For example, to set an identifier of 97 for unit D97, use the following command:

```
SET D97 IDENTIFIER=97
```

Using SWCC to Specify LUN ID Alias for a Virtual Disk

Setting a LUN ID alias for a virtual disk is the same as setting a unit identifier. To set LUN ID alias for a previously created virtual disk perform the following procedure:

1. Open the storage window, where you see the properties for that virtual disk.
2. Click on the Settings Tab to see changeable properties.
3. Click on the “Enable LUN ID Alias” button.
4. Enter the LUN ID alias (identifier) in the appropriate field. It is strongly suggested that, for simplicity, the LUN ID alias match the virtual disk number.

Selective Storage Presentation

Selective Storage presentation is a feature of the HSG80 controller that enables the user to control the allocation of storage space and shared access to storage across multiple hosts. This is also known as *Restricting Host Access*.

In a subsystem that is attached to more than one host or if the hosts have more than one adapter, it is possible to reserve certain units for the exclusive use of certain host connections.

NOTE: The default condition is `ENABLE_ACCESS_PATH=ALL`. This specifies that access paths to ALL hosts are enabled. It is recommended that the user restrict host access and that the access path be carefully specified to avoid providing undesired host connections access to the unit.

ADD UNIT (or SET *unit*)

Restricting Host Access in Multiple-Bus Failover Mode

In multiple-bus mode, the units assigned to any port are visible to all ports. There are two ways to limit host access in multiple-bus failover mode:

- Enabling the access path of selected host connections
- Setting offsets

Enable the Access Path of Selected Host Connections

Host access can be limited by enabling the access of certain host connections and disabling the access of others. This is done through the *ENABLE_ACCESS_PATH* and *DISABLE_ACCESS_PATH* switches of the *ADD UNIT* (or *SET unit*) commands. Access path is a unit switch, meaning it must be specified for each unit. Default access means that the unit is accessible to all hosts. It is important to remember that at least two paths between the unit and the host must be enabled in order for multiple-bus failover to work.

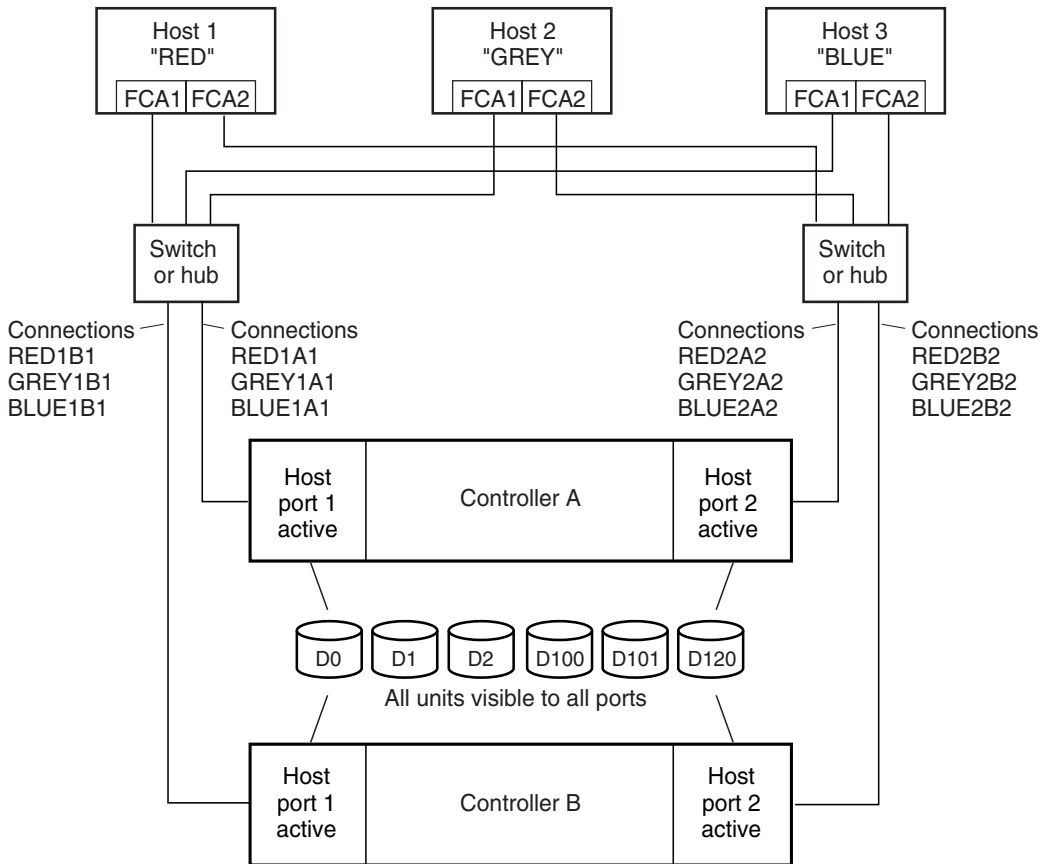

NOTE: FCA = Fibre Channel Adapter

CXO7078B

Figure 1-8. Limiting host access in multiple-bus failover mode

For example:

Figure 1-8 shows a representative multiple-bus failover configuration. Restricting the access of unit D101 to host BLUE can be done by enabling only the connections to host BLUE. At least two connections must be enabled for multiple-bus failover to work. For most operating systems, it is desirable to have all connections to the host enabled. To enable all connections for host BLUE, enter the following commands:

```
SET D101 DISABLE_ACCESS_PATH=ALL
SET D101 ENABLE_ACCESS_PATH=BLUE1A1,BLUE1B1,BLUE2A2,BLUE2B2
```

To enable only two connections for host BLUE (if it is a restriction of the operating system), select two connections that use different adapters, different switches or hubs, and different controllers:

```
SET D101 DISABLE_ACCESS_PATH=ALL
SET D101 ENABLE_ACCESS_PATH=(BLUE1A1,BLUE2B2)
```

or

```
SET D101 DISABLE_ACCESS_PATH=ALL
SET D101 ENABLE_ACCESS_PATH=(BLUE1B1,BLUE2A2)
```

If the storage subsystem has more than one host connection, the access path must be specified carefully to avoid giving undesirable host connections access to the unit. The default condition for a unit is that access paths to all host connections are enabled. To restrict host access to a set of host connections, specify *DISABLE_ACCESS_PATH=ALL* when the unit is added, then use the SET *unit* command to specify the set of host connections that are to have access to the unit.

Enabling the access path to a particular host connection does not override previously enabled access paths. All access paths previously enabled are still valid; the new host connection is simply added to the list of connections that can access the unit.

IMPORTANT: The procedure of restricting access by enabling all access paths then disabling selected paths is **not recommended** because of the potential data/security breach that occurs when a new host connection is added.

Restricting Host Access by Offsets

Offsets establish the start of the range of units that a host connection can access. However, depending on the operating system, hosts that have lower offsets may be able to access the units in the specified range.

NOTE: All host connections to the same host computer must be set to the same offset.

For example:

In Figure 1-8, assume all host connections initially have the default offset of 0. Giving all connections access to host BLUE, an offset of 120 will present unit D120 to host BLUE as LUN 0. Enter the following commands:

```
SET BLUE1A1 UNIT_OFFSET=120
SET BLUE1B1 UNIT_OFFSET=120
SET BLUE2A2 UNIT_OFFSET=120
SET BLUE2B2 UNIT_OFFSET=120
```

Host BLUE cannot see units lower than its offset, so it cannot access any other units. However, the other two hosts can still access D120 as LUN 20 if their operating system permits. To restrict access of D120 to only host BLUE, enable only host BLUE's access, as follows:

```
SET D120 DISABLE_ACCESS_PATH=ALL
SET D120 ENABLE_ACCESS_PATH=(BLUE1A1,BLUE1B1,BLUE1A2,BLUE2B2)
```

NOTE: Compaq recommends that you always provide access to only specific connections. This way, if new connections are added, they will not have automatic access to all units. See "Restricting Host Access in Multiple-Bus Failover Mode," page 1-15.

Worldwide Names (Node IDs and Port IDs)

A worldwide name—also called a node ID—is a unique, 64-bit number assigned to a subsystem prior to shipping. The node ID belongs to the subsystem itself and never changes.

Each subsystem's node ID ends in zero, for example 5000-1FE1-FF0C-EE00. The controller port IDs are derived from the node ID.

In multiple-bus failover mode, each of the host ports has its own port ID:

- Controller B, port 1—worldwide name + 1, for example 5000-1FE1-FF0C-EE01
- Controller B, port 2—worldwide name + 2, for example 5000-1FE1-FF0C-EE02
- Controller A, port 1—worldwide name + 3, for example 5000-1FE1-FF0C-EE03
- Controller A, port 2—worldwide name + 4, for example 5000-1FE1-FF0C-EE04

Use the CLI command, `SHOW THIS_CONTROLLER/OTHER_CONTROLLER` to display the subsystem's worldwide name.

Restoring Worldwide Names (Node IDs)

If a situation occurs that requires you to restore the worldwide name, you can restore it using the worldwide name and checksum printed on the sticker on the frame into which the controller is inserted.

Figure 1-9 shows the placement of the worldwide name label for the Model 2200 enclosure, and Figure 1-10 for the BA370 enclosure.

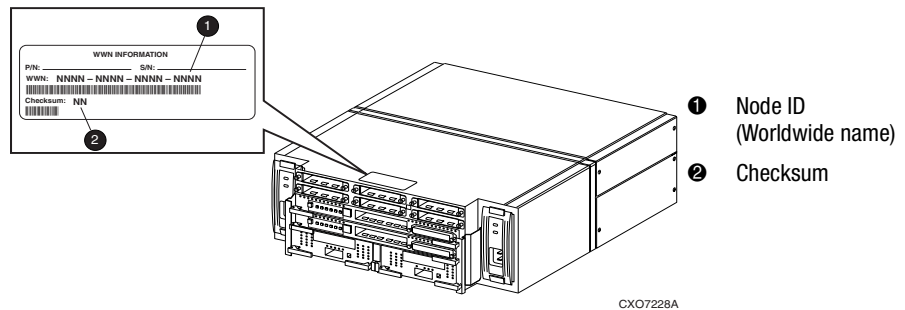

Figure 1-9. Placement of the worldwide name label on the Model 2200 enclosure

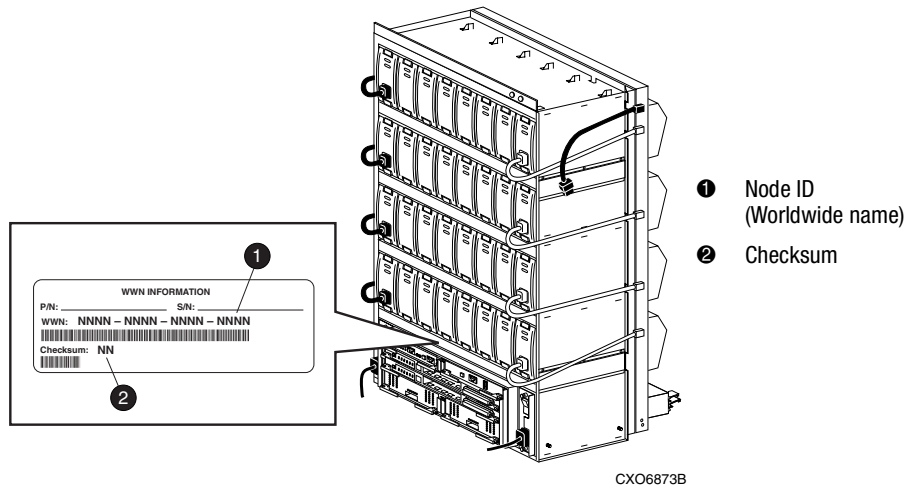

Figure 1-10. Placement of the worldwide name label on the BA370 enclosure



CAUTION: Each subsystem has its own unique worldwide name (node ID). If you attempt to set the subsystem worldwide name to a name other than the one that came with the subsystem, the data on the subsystem will not be accessible. Never set two subsystems to the same worldwide name, or data corruption will occur.

Unit Worldwide Names (LUN IDs)

In addition, each unit has its own worldwide name, or LUN ID. This is a unique, 128-bit value that the controller assigns at the time of unit initialization. It cannot be altered by the user but does change when the unit is reinitialized. Use the `SHOW` command to list the LUN ID.

Chapter 2

Planning Storage

This chapter provides information to help you plan the storage configuration of your subsystem. Use the guidelines found in this section to plan the various types of storage containers needed.

The following information is included in this chapter:

- “Where to Start,” page 2–2
- “Configuration Rules,” page 2–3
- “Device PTL Addressing Convention,” page 2–3
- “Determining Storage Requirements,” page 2–10
- “Choosing a Container Type,” page 2–11
- “Creating a Stageset Profile,” page 2–12
- “Stageset Planning Considerations,” page 2–14
- “Stageset Expansion Considerations,” page 2–21
- “Partition Planning Considerations,” page 2–22
- “Changing Characteristics through Switches,” page 2–23
- “Stageset and Partition Switches,” page 2–24
- “Initialization Switches,” page 2–25
- “Unit Switches,” page 2–29
- “Storage Maps,” page 2–29

Where to Start

The following procedure outlines the steps to follow when planning your storage configuration. Containers are individual disk drives (JBOD), storageset types (mirrorsets, stripesets, and so on), and/or partitioned drives. See Appendix A to locate the blank templates for keeping track of the containers being configured.

1. Review configuration rules. See “Configuration Rules,” page 2–3.
2. Familiarize yourself with the current physical layout of the devices and their addressing scheme. See “Device PTL Addressing Convention,” page 2–3.
3. Determine your storage requirements. Use the questions in “Determining Storage Requirements,” page 2–10, to help you.
4. Choose the type of storage containers you need to use in your subsystem. See “Choosing a Container Type,” page 2–11, for a comparison and description of each type of storageset.
5. Create a storageset profile (described in “Creating a Storageset Profile,” page 2–12). Fill out the storageset profile while you read the sections that pertain to your chosen storage type:
 - “Storageset Planning Considerations,” page 2–14
 - “Mirrorset Planning Considerations,” page 2–16
 - “RAIDset Planning Considerations,” on page 18
 - “Partition Planning Considerations,” page 2–22
 - “Striped Mirrorset Planning Considerations,” page 2–20
6. Decide which switches you need for your subsystem. General information on switches is detailed in “Storageset and Partition Switches,” page 2–24.
 - Determine the unit switches you want for your units (“Unit Switches,” page 2–29).
 - Determine the initialization switches you want for your planned storage containers (“Initialization Switches,” page 2–25).
7. Create a storage map (“Storage Maps,” page 2–29).
8. Configure the storage you have now planned using one of the following methods:
 - Use SWCC. See the SWCC documentation for details.
 - Use the Command Line Interpreter (CLI) commands. This method allows you flexibility in defining and naming your storage containers. See the *Compaq StorageWorks HSG80 Array Controller ACS Version 8.6 CLI Reference Guide*.

Configuration Rules

Review the following requirements and conditions to ensure that the storage configuration you are planning is adequate:

- Maximum of 128 LUNs: if Command Console LUN (CCL) is enabled, the result is 127 visible LUNs and one CCL
- Maximum 1.024 TB LUN capacity
- Maximum 84 physical drives with 2 optional expansion enclosures per storage system
- Maximum 84 physical devices
- Maximum 20 RAID-5 storagesets
- Maximum 8 partitions per storageset or individual disk
- Maximum 6 physical devices per RAID 1 (mirrorset)
- Maximum 14 physical devices per RAID-5 storageset
- Maximum 24 physical devices per RAID 0 (stripeset)
- Maximum 24 physical devices per striped mirrorset

Device PTL Addressing Convention

The HSG80 controller has six SCSI device ports, each of which connects to a SCSI bus. In dual-controller subsystems, these device buses are shared between the two controllers. (The StorageWorks Command Console GUI calls the device ports “channels.”) The standard BA370 enclosure provides a maximum of four SCSI target identifications (ID) for each device port. If more target IDs are needed, expansion enclosures can be added to the subsystem.

The HSG80 controller identifies devices based on a Port-Target-LUN (PTL) numbering scheme, shown in Figure 2-1. The physical location of a device in its enclosure determines its PTL.

- P—Designates the controller's SCSI device port number (1 through 6).
- T—Designates the target ID number of the device. Valid target ID numbers for a single-controller configuration and dual-redundant controller configuration are 0 - 3 and 8 - 15, respectively.
- L—Designates the logical unit (LUN) of the device. For disk devices the LUN is always 0.

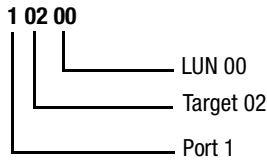
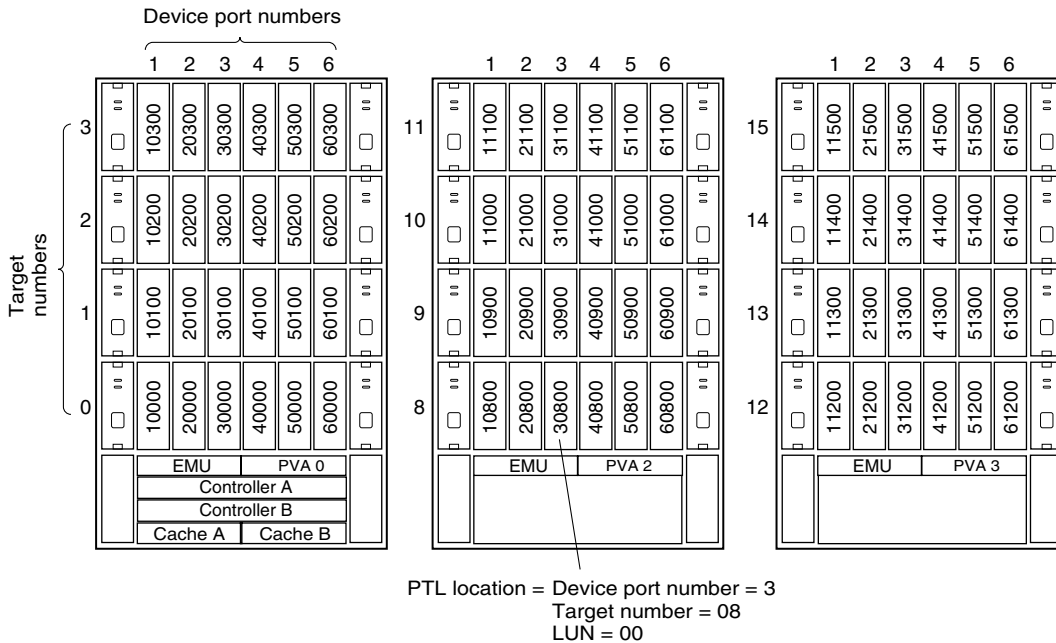

Figure 2-1. PTL naming convention

The controller can either operate with a BA370 enclosure or with a Model 2200 controller enclosure combined with Model 4214R, Model 4254, Model 4310R, Model 4350R, Model 4314R, or Model 4354R disk enclosures.

The controller operates with BA370 enclosures that are assigned ID numbers 0, 2, and 3. These ID numbers are set through the PVA module. Enclosure ID number 1, which assigns devices to targets 4 through 7, is not supported. Figure 2-2 shows the addresses for each device in an extended configuration.



CXO5851B

Figure 2-2. PTL addressing in a configuration in a BA370 enclosure

The Model 2200 controller enclosure can be combined with the following:

- **Model 4214R disk enclosure** — Ultra2 SCSI with 14 drive bays, single-bus I/O module.
- **Model 4254 disk enclosure** — Ultra2 SCSI with 14 drive bays, dual-bus I/O module.

NOTE: The Model 4214R uses the same storage maps as the Model 4314R, and the Model 4254 uses the same storage maps as the Model 4354R disk enclosures.

- **Model 4310R disk enclosure** — Ultra3 SCSI with 10 drive bays, single-bus I/O module. Figure 2-3 shows the addresses for each device in a six-shelf, single-bus configuration. A maximum of six Model 4310R disk enclosures can be used with each Model 2200 controller enclosure.

NOTE: The storage map for the Model 4310R reflects the disk enclosure's physical location in the rack. Disk enclosures 6, 5, and 4 are stacked above the controller enclosure, and disk enclosures 1, 2, and 3 are stacked below the controller enclosure.

- **Model 4350R disk enclosure** — Ultra3 SCSI with 10 drive bays, dual-bus I/O module. Figure 2-4 shows the addresses for each device in a three-shelf, dual-bus configuration. A maximum of three Model 4350R disk enclosures can be used with each Model 2200 controller enclosure.

- **Model 4314R disk enclosure** — Ultra3 SCSI with 14 drive bays, single-bus I/O module. Figure 2-5 shows the addresses for each device in a six-shelf, single-bus configuration. A maximum of six Model 4314R disk enclosures can be used with each Model 2200 controller enclosure.

NOTE: The storage map for the Model 4314R reflects the disk enclosure's physical location in the rack. Disk enclosures 6, 5, and 4 are stacked above the controller enclosure, and disk enclosures 1, 2, and 3 are stacked below the controller enclosure.

- **Model 4354R disk enclosure** — Ultra3 SCSI with 14 drive bays, dual-bus I/O module. Figure 2-6 shows the addresses for each device in a three-shelf, dual-bus configuration. A maximum of three Model 4354R disk enclosures can be used with each Model 2200 controller enclosure.

NOTE: Appendix A contains storageset profiles you can copy and use to create your own system profiles. It also contains an enclosure template you can use to help you keep track of the location of devices and storagesets in your shelves.

Model 4310R Disk Enclosure Shelf 6 (single-bus)

Bay	1	2	3	4	5	6	7	8	9	10
SCSI ID	00	01	02	03	04	05	08	10	11	12
DISK ID	Disk60000	Disk60100	Disk60200	Disk60300	Disk60400	Disk60500	Disk60800	Disk61000	Disk61100	Disk61200

Model 4310R Disk Enclosure Shelf 5 (single-bus)

Bay	1	2	3	4	5	6	7	8	9	10
SCSI ID	00	01	02	03	04	05	08	10	11	12
DISK ID	Disk50000	Disk50100	Disk50200	Disk50300	Disk50400	Disk50500	Disk50800	Disk51000	Disk51100	Disk51200

Model 4310R Disk Enclosure Shelf 4 (single-bus)

Bay	1	2	3	4	5	6	7	8	9	10
SCSI ID	00	01	02	03	04	05	08	10	11	12
DISK ID	Disk40000	Disk40100	Disk40200	Disk40300	Disk40400	Disk40500	Disk40800	Disk41000	Disk41100	Disk41200

Model 4310R Disk Enclosure Shelf 1 (single-bus)

Bay	1	2	3	4	5	6	7	8	9	10
SCSI ID	00	01	02	03	04	05	08	10	11	12
DISK ID	Disk10000	Disk10100	Disk10200	Disk10300	Disk10400	Disk10500	Disk10800	Disk11000	Disk11100	Disk11200

Model 4310R Disk Enclosure Shelf 2 (single-bus)

Bay	1	2	3	4	5	6	7	8	9	10
SCSI ID	00	01	02	03	04	05	08	10	11	12
DISK ID	Disk20000	Disk20100	Disk20200	Disk20300	Disk20400	Disk20500	Disk20800	Disk21000	Disk21100	Disk21200

Model 4310R Disk Enclosure Shelf 3 (single-bus)

Bay	1	2	3	4	5	6	7	8	9	10
SCSI ID	00	01	02	03	04	05	08	10	11	12
DISK ID	Disk30000	Disk30100	Disk30200	Disk30300	Disk30400	Disk30500	Disk30800	Disk31000	Disk31100	Disk31200

Figure 2-3. PTL addressing in a single-bus configuration, six Model 4310R disk enclosures

Model 4350R Disk Enclosure Shelf 1 (dual-bus)

	SCSI Bus A					SCSI Bus B				
Bay	1	2	3	4	5	6	7	8	9	10
SCSI ID	00	01	02	03	04	00	01	02	03	04
DISK ID	Disk10000	Disk10100	Disk10200	Disk10300	Disk10400	Disk20000	Disk20100	Disk20200	Disk20300	Disk20400

Model 4350R Disk Enclosure Shelf 2 (dual-bus)

	SCSI Bus A					SCSI Bus B				
Bay	1	2	3	4	5	6	7	8	9	10
SCSI ID	00	01	02	03	04	00	01	02	03	04
DISK ID	Disk30000	Disk30100	Disk30200	Disk30300	Disk30400	Disk40000	Disk40100	Disk40200	Disk40300	Disk40400

Model 4350R Disk Enclosure Shelf 3 (dual-bus)

	SCSI Bus A					SCSI Bus B				
Bay	1	2	3	4	5	6	7	8	9	10
SCSI ID	00	01	02	03	04	00	01	02	03	04
DISK ID	Disk50000	Disk50100	Disk50200	Disk50300	Disk50400	Disk60000	Disk60100	Disk60200	Disk60300	Disk60400

Figure 2-4. PTL addressing in a dual-bus configuration, three Model 4350R disk enclosures

Model 4314R Disk Enclosure Shelf 6 (single-bus)

Bay	1	2	3	4	5	6	7	8	9	10	11	12	13	14
SCSI ID	00	01	02	03	04	05	08	09	10	11	12	13	14	15
DISK ID	Disk60000	Disk60100	Disk60200	Disk60300	Disk60400	Disk60500	Disk60800	Disk60900	Disk61000	Disk61100	Disk61200	Disk61300	Disk61400	Disk61500

Model 4314R Disk Enclosure Shelf 5 (single-bus)

Bay	1	2	3	4	5	6	7	8	9	10	11	12	13	14
SCSI ID	00	01	02	03	04	05	08	09	10	11	12	13	14	15
DISK ID	Disk50000	Disk50100	Disk50200	Disk50300	Disk50400	Disk50500	Disk50800	Disk50900	Disk51000	Disk51100	Disk51200	Disk51300	Disk51400	Disk51500

Model 4314R Disk Enclosure Shelf 4 (single-bus)

Bay	1	2	3	4	5	6	7	8	9	10	11	12	13	14
SCSI ID	00	01	02	03	04	05	08	09	10	11	12	13	14	15
DISK ID	Disk40000	Disk40100	Disk40200	Disk40300	Disk40400	Disk40500	Disk40800	Disk40900	Disk41000	Disk41100	Disk41200	Disk41300	Disk41400	Disk41500

Model 4314R Disk Enclosure Shelf 1 (single-bus)

Bay	1	2	3	4	5	6	7	8	9	10	11	12	13	14
SCSI ID	00	01	02	03	04	05	08	09	10	11	12	13	14	15
DISK ID	Disk10000	Disk10100	Disk10200	Disk10300	Disk10400	Disk10500	Disk10800	Disk10900	Disk11000	Disk11100	Disk11200	Disk11300	Disk11400	Disk11500

Model 4314R Disk Enclosure Shelf 2 (single-bus)

Bay	1	2	3	4	5	6	7	8	9	10	11	12	13	14
SCSI ID	00	01	02	03	04	05	08	09	10	11	12	13	14	15
DISK ID	Disk20000	Disk20100	Disk20200	Disk20300	Disk20400	Disk20500	Disk20800	Disk20900	Disk21000	Disk21100	Disk21200	Disk21300	Disk21400	Disk21500

Model 4314R Disk Enclosure Shelf 3 (single-bus)

Bay	1	2	3	4	5	6	7	8	9	10	11	12	13	14
SCSI ID	00	01	02	03	04	05	08	09	10	11	12	13	14	15
DISK ID	Disk30000	Disk30100	Disk30200	Disk30300	Disk30400	Disk30500	Disk30800	Disk30900	Disk31000	Disk31100	Disk31200	Disk31300	Disk31400	Disk31500

Figure 2-5. PTL addressing in a single-bus configuration, six Model 4314R disk enclosures

Model 4354R Disk Enclosure Shelf 1 (dual-bus)

	SCSI Bus A							SCSI Bus B						
Bay	1	2	3	4	5	6	7	8	9	10	11	12	13	14
SCSI ID	00	01	02	03	04	05	08	00	01	02	03	04	05	08
DISK ID	Disk10000	Disk10100	Disk10200	Disk10300	Disk10400	Disk10500	Disk10800	Disk20000	Disk20100	Disk20200	Disk20300	Disk20400	Disk20500	Disk20800

Model 4354R Disk Enclosure Shelf 2 (dual-bus)

	SCSI Bus A							SCSI Bus B						
Bay	1	2	3	4	5	6	7	8	9	10	11	12	13	14
SCSI ID	00	01	02	03	04	05	08	00	01	02	03	04	05	08
DISK ID	Disk30000	Disk30100	Disk30200	Disk30300	Disk30400	Disk30500	Disk30800	Disk40000	Disk40100	Disk40200	Disk40300	Disk40400	Disk40500	Disk40800

Model 4354R Disk Enclosure Shelf 3 (dual-bus)

	SCSI Bus A							SCSI Bus B						
Bay	1	2	3	4	5	6	7	8	9	10	11	12	13	14
SCSI ID	00	01	02	03	04	05	08	00	01	02	03	04	05	08
DISK ID	Disk50000	Disk50100	Disk50200	Disk50300	Disk50400	Disk50500	Disk50800	Disk60000	Disk60100	Disk60200	Disk60300	Disk60400	Disk60500	Disk60800

Figure 2-6. PTL addressing in a dual-bus configuration, three Model 4354R disk enclosures

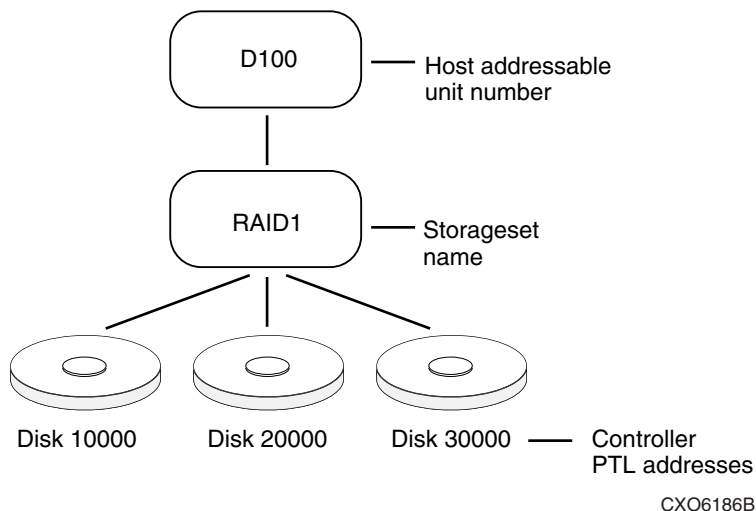

Figure 2-7. Mapping a unit to physical disk drives

Determining Storage Requirements

It is important to determine your storage requirements. Here are a few of the questions you should ask yourself regarding the subsystem usage:

- What applications or user groups will access the subsystem? How much capacity do they need?
- What are the I/O requirements? If an application is data transfer-intensive, what is the required transfer rate? If it is I/O request-intensive, what is the required response time? What is the read/write ratio for a typical request?
- Are most I/O requests directed to a small percentage of the disk drives? Do you want to keep it that way or balance the I/O load?
- Do you store mission-critical data? Is availability the highest priority or would standard backup procedures suffice?

Choosing a Container Type

Different applications may have different storage requirements. You probably want to configure more than one kind of container within your subsystem.

In choosing a container, you choose between independent disks (JBODs) or one of several storageset types, as shown in Figure 2-8. The independent disks and the selected storageset may also be partitioned.

The storagesets implement RAID (Redundant Array of Independent Disks) technology. Consequently, they all share one important feature: each storageset, whether it contains two disk drives or ten, looks like one large, virtual disk drive to the host.

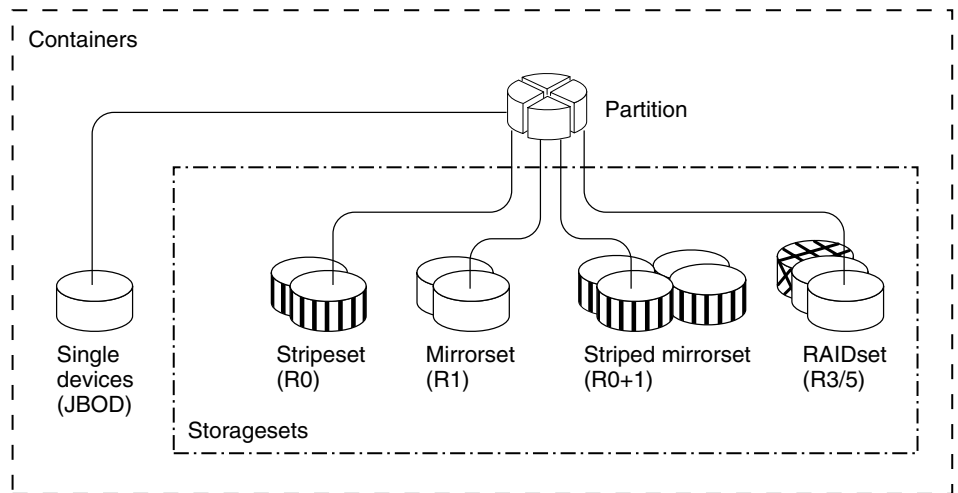

CXO6677A

Figure 2-8. Container types

Table 2-1 compares the different kinds of containers to help you determine which ones satisfy your requirements.

Container Name	Relative Availability	Request Rate (Read/Write) I/O per second	Transfer Rate (Read/Write) MB per second	Applications
Independent disk drives (JBOD)	Equal to number of JBOD disk drives	Comparable to single disk drive	Comparable to single disk drive	—
Stripeset (RAID 0)	Proportionate to number of disk drives; worse than single disk drive	Excellent if used with large chunk size	Excellent if used with small chunk size	High performance for non-critical data
Mirrorset (RAID1)	Excellent	Good/Fair	Good/Fair	System drives; critical files
RAIDset (RAID 3/5)	Excellent	Excellent/good	Read: excellent (if used with small chunk sizes) Write: good (if used with small chunk sizes)	High request rates, read-intensive, data lookup
Striped Mirrorset (RAID 0+1)	Excellent	Excellent if used with large chunk size	Excellent if used with small chunk size	Any critical response-time application

For a comprehensive discussion of RAID, refer to *The RAIDBOOK—A Source Book for Disk Array Technology*.

Creating a Storageset Profile

Creating a profile for your storagesets, partitions, and devices can simplify the configuration process. Filling out a storageset profile helps you choose the storagesets that best suit your needs and to make informed decisions about the switches you can enable for each storageset or storage device that you configure in your subsystem.

See the example storageset profile shown in Figure 2-9. Appendix A contains blank profiles that you can copy and use to record the details for your storagesets. Use the information in this chapter to help you make decisions when creating storageset profiles.

Type of Storageset:

<input type="checkbox"/> Mirrorset	<input checked="" type="checkbox"/> RAIDset	<input type="checkbox"/> Stripeset	<input type="checkbox"/> Striped Mirrorset	<input type="checkbox"/> JBOD
------------------------------------	---	------------------------------------	--	-------------------------------

Storageset Name *R1*

Disk Drives *D10300, D20300, D10400, D20400*

Unit Number *D101*

Partitions:

Unit #	Unit #	Unit #	Unit #	Unit #	Unit #	Unit #	Unit #
%	%	%	%	%	%	%	%

RAIDset Switches:

Reconstruction Policy	Reduced Membership	Replacement Policy
<input checked="" type="checkbox"/> Normal (default)	<input checked="" type="checkbox"/> No (default)	<input checked="" type="checkbox"/> Best performance (default)
<input type="checkbox"/> Fast	<input type="checkbox"/> Yes, missing:	<input type="checkbox"/> Best fit
		<input type="checkbox"/> None

Mirrorset Switches:

Replacement Policy	Copy Policy	Read Source
<input type="checkbox"/> Best performance (default)	<input type="checkbox"/> Normal (default)	<input type="checkbox"/> Least busy (default)
<input type="checkbox"/> Best fit	<input type="checkbox"/> Fast	<input type="checkbox"/> Round robin
<input type="checkbox"/> None		<input type="checkbox"/> Disk drive:

Initialize Switches:

Chunk size	Save Configuration	Metadata
<input checked="" type="checkbox"/> Automatic (default)	<input type="checkbox"/> No (default)	<input checked="" type="checkbox"/> Destroy (default)
<input type="checkbox"/> 64 blocks	<input checked="" type="checkbox"/> Yes	<input type="checkbox"/> Retain
<input type="checkbox"/> 128 blocks		
<input type="checkbox"/> 256 blocks		
<input type="checkbox"/> Other:		

Unit Switches:

Caching	Access by following hosts enabled
Read caching <input checked="" type="checkbox"/>	<u>ALL</u>
Read-ahead caching <input type="checkbox"/>	_____
Write-back caching <input checked="" type="checkbox"/>	_____
Write-through caching <input type="checkbox"/>	_____

Figure 2-9. An example storageset profile

Storageset Planning Considerations

This section contains the guidelines for choosing the storageset type needed for your subsystem:

- “Stripeset Planning Considerations,” page 2-14
- “Mirrorset Planning Considerations,” page 2-16
- “RAIDset Planning Considerations,” page 2-18
- “Striped Mirrorset Planning Considerations,” page 2-20
- “Storageset Planning Considerations,” page 2-14
- “Partition Planning Considerations,” page 2-22

Stripeset Planning Considerations

Stripesets (RAID 0) enhance I/O performance by spreading the data across multiple disk drives. Each I/O request is broken into small segments called “chunks.” These chunks are then simultaneously “striped” across the disk drives in the storageset, thereby enabling several disk drives to participate in one I/O request.

For example, in a three-member stripeset that contains disk drives Disk 10000, Disk 20000, and Disk 10100, the first chunk of an I/O request is written to Disk 10000, the second to Disk 20000, the third to Disk 10100, the fourth to Disk 10000, and so forth until all of the data has been written to the drives (Figure 2-10).

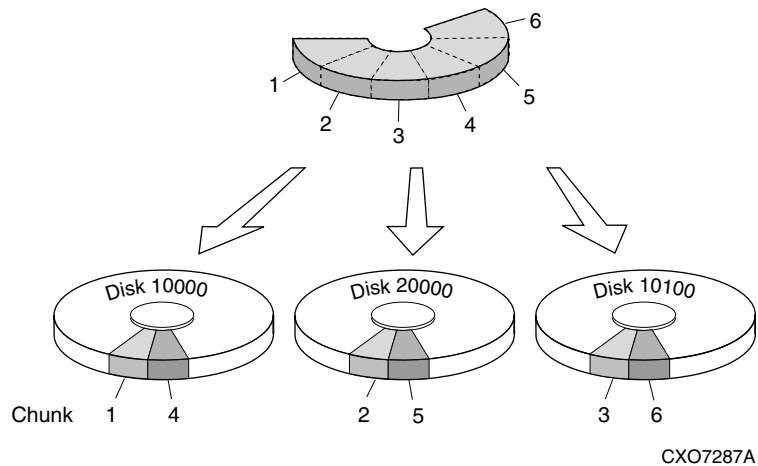

Figure 2-10. A 3-member RAID 0 stripeset (example 1)

The relationship between the chunk size and the average request size determines if striping maximizes the request rate or the data-transfer rate. You can set the chunk size or use the default setting (see “Chunk Size,” page 2-26, for information about setting the chunk size). Figure 2-11 shows another example of a three-member RAID 0 stripeset.

A major benefit of striping is that it balances the I/O load across all of the disk drives in the storageset. This can increase the subsystem performance by eliminating the hot spots (high localities of reference) that occur when frequently accessed data becomes concentrated on a single disk drive.

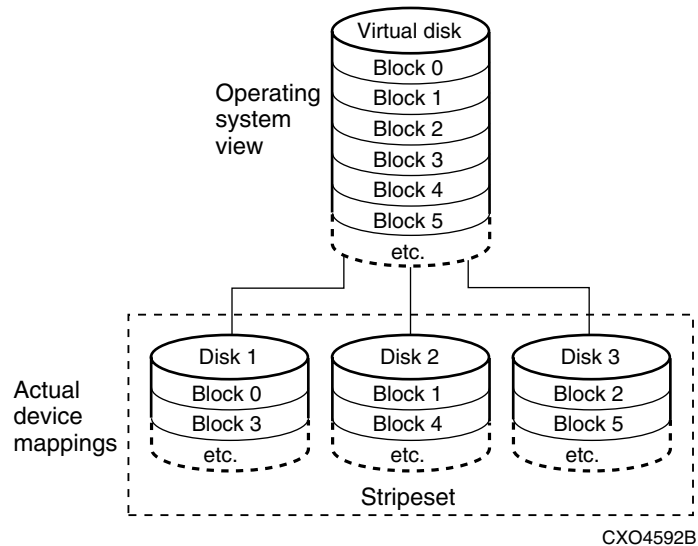

Figure 2-11. A 3-member RAID 0 stripeset (example 2)

Keep the following points in mind as you plan your stripesets:

- Reporting methods and size limitations prevent certain operating systems from working with large stripesets.
- A storageset should only contain disk drives of the same capacity. The controller limits the effective capacity of each member to the capacity of the smallest member in the storageset (base member size) when the storageset is initialized. Thus, if you combine 9 GB disk drives with 4 GB disk drives in the same storageset, you waste 5 GB of capacity on each 9 GB member.

If you need high performance and high availability, consider using a RAIDset, striped-mirrorset, or a host-based shadow of a stripeset.

- Striping does not protect against data loss. In fact, because the failure of one member is equivalent to the failure of the entire stripeset, the likelihood of losing data is higher for a stripeset than for a single disk drive.

For example, if the mean time between failures (MTBF) for a single disk is 1 hour, then the MTBF for a stripeset that comprises N such disks is 1/N hours. As another example, if the MTBF of a single disk is 150,000 hours (about 17 years), a stripeset comprising four of these disks would only have an MTBF of slightly more than 4 years.

For this reason, you should avoid using a stripeset to store critical data. Stripesets are more suitable for storing data that can be reproduced easily or whose loss does not prevent the system from supporting its critical mission.

- Evenly distribute the members across the device ports to balance the load and provide multiple paths.
- Stripesets may contain between two and 24 members.
- If you plan to use mirror members to replace failing drives, then create the original stripeset as a stripeset of 1-member mirrorsets.
- Stripesets are well-suited for the following applications:
 - Storing program image libraries or run-time libraries for rapid loading.
 - Storing large tables or other structures of read-only data for rapid application access.
 - Collecting data from external sources at very high data transfer rates.
- Stripesets are not well-suited for the following applications:
 - A storage solution for data that cannot be easily reproduced or for data that must be available for system operation.
 - Applications that make requests for small amounts of sequentially located data.
 - Applications that make synchronous random requests for small amounts of data.

Spread the member drives as evenly as possible across the six I/O device ports.

Mirrorset Planning Considerations

Mirrorsets (RAID 1) use redundancy to ensure availability, as illustrated in Figure 2-12. For each primary disk drive, there is at least one mirror disk drive. Thus, if a primary disk drive fails, its mirror drive immediately provides an exact copy of the data. Figure 2-13 shows a second example of a Mirrorset.

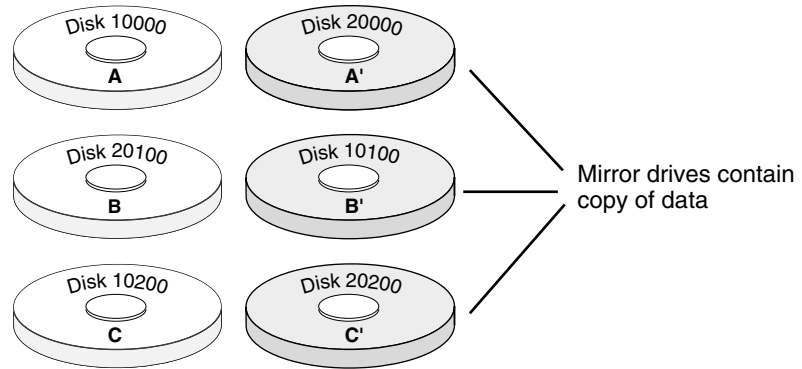

CXO7288A

Figure 2-12. Mirrorsets maintain two copies of the same data

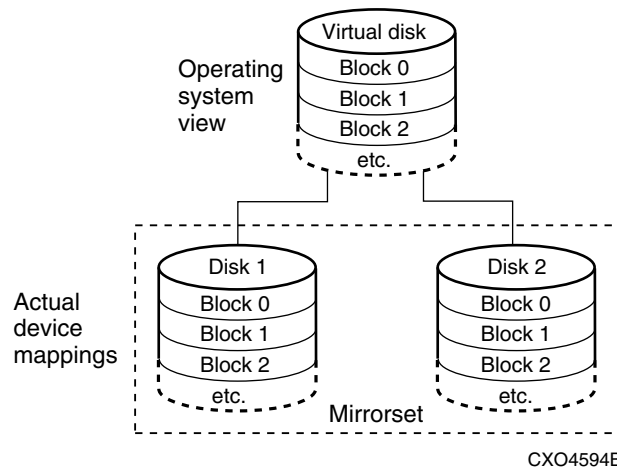

CXO4594B

Figure 2-13. Mirrorset example 2

Keep these points in mind when planning mirrorsets:

- Data availability with a mirrorset is excellent but comes with a higher cost—you need twice as many disk drives to satisfy a given capacity requirement. If availability is your top priority, consider using dual-redundant controllers and redundant power supplies.
- You can configure up to 20 mirrorsets per controller or pair of dual-redundant controllers. Each mirrorset may contain up to 6 members.
- Both write-back cache modules must be the same size.

- A mirrorset should only contain disk drives of the same capacity.
- Spread mirrorset members across different device ports (drive bays).
- Mirrorsets are well-suited for the following:
 - ❑ Any data for which reliability requirements are extremely high
 - ❑ Data to which high-performance access is required
 - ❑ Applications for which cost is a secondary issue
- Mirrorsets are not well-suited for the following applications:
 - ❑ Write-intensive applications (a performance hit of 10 percent will occur)
 - ❑ Applications for which cost is a primary issue

RAIDset Planning Considerations

RAIDsets (RAID 3/5) are enhanced stripesets—they use striping to increase I/O performance and distributed-parity data to ensure data availability. Figure 2-14 shows an example of a RAIDset that uses five members.

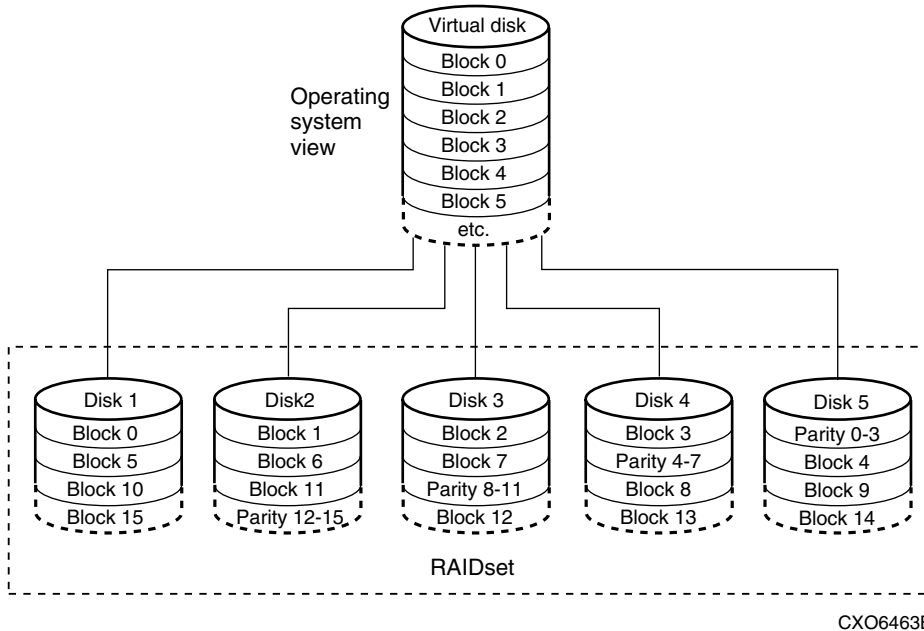

Figure 2-14. A 5-member RAIDset using parity

RAIDsets are similar to stripesets in that the I/O requests are broken into smaller “chunks” and striped across the disk drives. RAIDsets also create chunks of parity data and stripe them across all the members of the RAIDset. Parity data is derived mathematically from the I/O data and enables the controller to reconstruct the I/O data if a single disk drive fails. Thus, it becomes possible to lose a disk drive without losing access to the data it contained. Data could be lost if a second disk drive fails before the controller replaces the first failed disk drive and reconstructs the data.

The relationship between the chunk size and the average request size determines if striping maximizes the request rate or the data-transfer rates. You can set the chunk size or use the default setting. See “Chunk Size,” page 2-26, for information about setting the chunk size.

Keep these points in mind when planning RAIDsets:

- Reporting methods and size limitations prevent certain operating systems from working with large RAIDsets.
- Both cache modules must be the same size.
- A RAIDset must include at least 3 disk drives, but no more than 14.
- A storageset should only contain disk drives of the same capacity. The controller limits the capacity of each member to the capacity of the smallest member in the storageset. Thus, if you combine 9 GB disk drives with 4 GB disk drives in the same storageset, you waste 5 GB of capacity on each 9 GB member.
- RAIDsets are particularly well-suited for the following:
 - Small to medium I/O requests
 - Applications requiring high availability
 - High read request rates
 - Inquiry-type transaction processing
- RAIDsets are not particularly well-suited for the following:
 - Write-intensive applications
 - Database applications in which fields are continually updated
 - Transaction processing

Striped Mirrorset Planning Considerations

Striped mirrorsets (RAID 0+1) are a configuration of stripesets whose members are also mirrorsets (Figure 2-15). Consequently, this kind of storageset combines the performance of striping with the reliability of mirroring. The result is a storageset with very high I/O performance and high data availability. Figure 2-16 shows a second example of a striped mirrorset using six members.

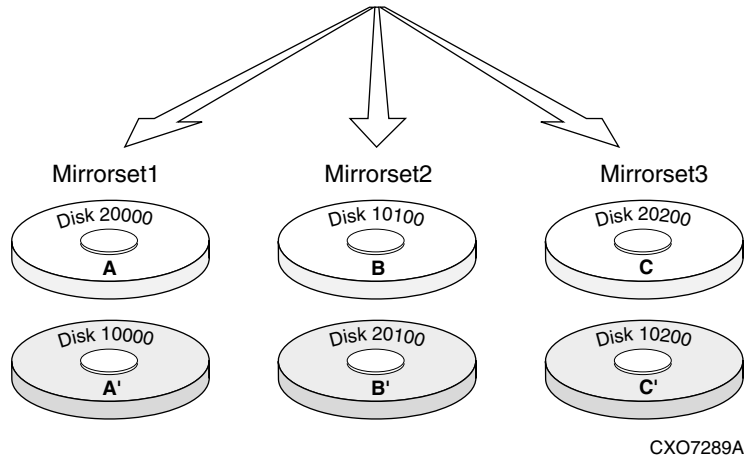

Figure 2-15. Striped mirrorset (example 1)

The failure of a single disk drive has no effect on the ability of the storageset to deliver data to the host. Under normal circumstances, a single disk drive failure has very little effect on performance. Because striped mirrorsets do not require any more disk drives than mirrorsets, this storageset is an excellent choice for data that warrants mirroring.

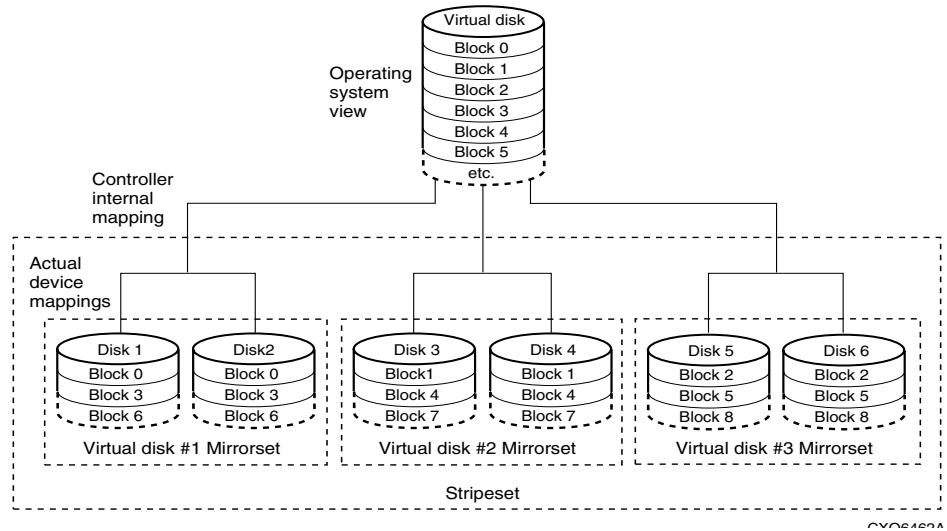

Figure 2-16. Striped mirrorset (example 2)

Plan the mirrorset members, and plan the stripeset that will contain them. Review the recommendations in “Stageset Planning Considerations,” page 2-14, and “Mirrorset Planning Considerations,” page 2-16.

Stageset Expansion Considerations

Stageset Expansion allows for the joining of two of the same kind of storage containers by concatenating RAIDsets, Stripesets, or individual disks, thereby forming a larger virtual disk which is presented as a single unit. The *Compaq StorageWorks HSG80 Array Controller ACS Version 8.6 CLI Reference Guide* describes the CLI command: ADD CONCATSETS which is used to perform concatenation.

CAUTION: The ADD CONCATSETS command should only be executed with host operating systems that support dynamic volume expansion. If the operating system cannot handle one of its disks increasing in size, use of this command could make data inaccessible.

Partition Planning Considerations

Use partitions to divide a container (storage set or individual disk drive) into smaller pieces, each of which can be presented to the host as its own storage unit. Figure 2-17 shows the conceptual effects of partitioning a single-disk container.

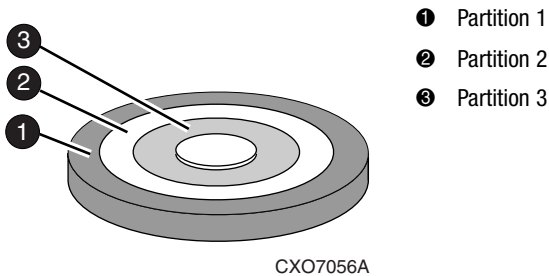

Figure 2-17. One example of a partitioned single-disk unit

You can create up to eight partitions per storage set (disk drive, RAID set, mirror set, stripe set, or striped mirror set). Each partition has its own unit number so that the host can send I/O requests to the partition just as it would to any unpartitioned storage set or device. Partitions are separately addressable storage units; therefore, you can partition a single storage set to service more than one user group or application.

Defining a Partition

Partitions are expressed as a percentage of the storage set or single disk unit that contains them:

- Mirror sets and single disk units—the controller allocates the largest whole number of blocks that are equal to or less than the percentage you specify.
- RAID sets and stripe sets—the controller allocates the largest whole number of stripes that are less than or equal to the percentage you specify.
 - ❑ Stripe sets—the stripe size = chunk size × number of members.
 - ❑ RAID sets—the stripe size = chunk size × (number of members minus 1)

An unpartitioned storage unit has more capacity than a partition that uses the whole unit because each partition requires a small amount of disk space for metadata.

Guidelines for Partitioning Storage Sets and Disk Drives

Keep these points in mind when planning partitions for storage sets and disks:

- Each storage set or disk drive may have up to eight partitions.
- In transparent failover mode, all partitions of a particular container must be on the same host port. Partitions cannot be split across host ports.
- In multiple-bus failover mode, all the partitions of a particular container must be on the same controller. Partitions cannot be split across controllers.
- Partitions cannot be combined into storage sets. For example, you cannot divide a disk drive into three partitions, then combine those partitions into a RAID set.
- Just as with storage sets, you do not have to assign unit numbers to partitions until you are ready to use them.
- The CLONE utility cannot be used with partitioned mirror sets or partitioned stripe sets. (See “Cloning Data for Backup,” page 8-2 for details about cloning.)

Changing Characteristics through Switches

CLI command switches allow the user another level of command options. There are three types of switches that modify the storage set and unit characteristics:

- Storage set switches
- Initialization switches
- Unit switches

The following sections describe how to enable/modify switches. They also contain a description of the major CLI command switches.

Enabling Switches

If you use SWCC to configure the device or storage set, you can set switches from the SWCC screens during the configuration process, and SWCC automatically applies them to the storage set or device. See the SWCC online help for information about using SWCC.

If you use CLI commands to configure the storageset or device manually, the configuration procedure found in Chapter 5 of this guide indicates when and how to enable each switch. The *Compaq StorageWorks HSG80 Array Controller ACS Version 8.6 CLI Reference Guide* contains the details of the CLI commands and their switches.

Changing Switches

You can change the RAIDset, mirrorset, device, and unit switches at any time. You cannot change the initialize switches without destroying data on the storageset or device. These switches are integral to the formatting and can only be changed by re-initializing the storageset.



CAUTION: Initializing a storageset is similar to formatting a disk drive; all data is destroyed during this procedure.

Storageset and Partition Switches

The characteristics of a particular storageset can be set by specifying switches when the storageset is added to the controllers' configuration. Once a storageset has been added, the switches can be changed by using a SET command. Switches can be set for partitions and the following types of storagesets:

- RAIDset
- Mirrorset

Stripesets have no specific switches associated with their ADD and SET commands.

RAIDset Switches

Use the following types of switches to control how a RAIDset ensures data availability:

- Replacement policy
- Reconstruction policy
- Remove/replace policy

For details on the use of these switches refer to SET RAIDSET and SET *RAIDset-name* commands in the *Compaq StorageWorks HSG80 Array Controller ACS Version 8.6 CLI Reference Guide*.

Mirrorset Switches

Use the following switches to control how a mirrorset behaves to ensure data availability:

- Replacement policy
- Copy speed
- Read source
- Membership

For details on the use of these switches refer to `ADD MIRRORSET` and `SET mirrorset-name` commands in the *Compaq StorageWorks HSG80 Array Controller ACS Version 8.6 CLI Reference Guide*.

Partition Switches

The following partition switches are available when creating a partition:

- Size
- Geometry

For details on the use of these switches refer to `CREATE_PARTITION` command in the *Compaq StorageWorks HSG80 Array Controller ACS Version 8.6 CLI Reference Guide*.

Initialization Switches

Initialization switches set characteristics for established storagesets before they are made into units. The following kinds of switches effect the format of a disk drive or storageset:

- Chunk Size (for stripesets and RAIDsets only)
- Save Configuration
- Destroy/Nodeestroy
- Geometry

Each of these switches is described in the following sections.

NOTE: After initializing the storageset or disk drive, you cannot change these switches without reinitializing the storageset or disk drive.

Chunk Size

Specify the chunk size of the data to be stored to control the stripesize used in RAIDsets and stripesets:

- *CHUNKSIZE=DEFAULT* lets the controller set the chunk size based on the number of disk drives (d) in a stripeset or RAIDset. If $d \leq 9$ then chunk size = 256. If $d > 9$ then chunk size = 128.
- *CHUNKSIZE=n* lets you specify a chunk size in blocks. The relationship between chunk size and request size determines whether striping increases the request rate or the data-transfer rate.

Increasing the Request Rate

A large chunk size (relative to the average request size) increases the request rate by enabling multiple disk drives to respond to multiple requests. If one disk drive contains all of the data for one request, then the other disk drives in the storageset are available to handle other requests. Thus, in principle, separate I/O requests can be handled in parallel, thereby increasing the request rate. This concept is shown in Figure 2-18.

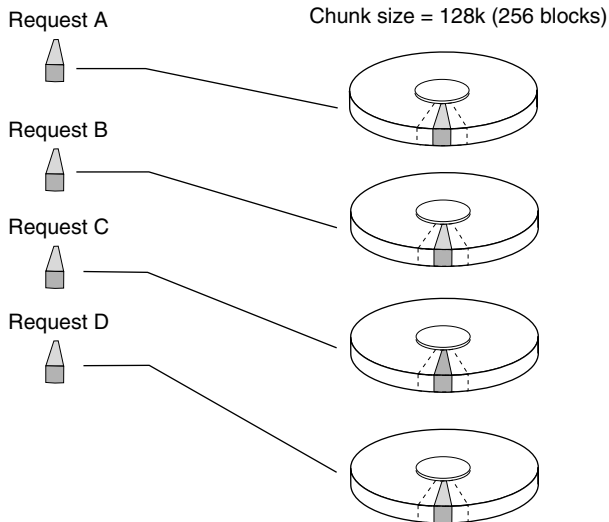

CXO-5135A-MC

Figure 2-18. Chunk size larger than the request size

Large chunk sizes also tend to increase the performance of random reads and writes. It is recommended that you use a chunk size of 10 to 20 times the average request size, rounded to the closest prime number. In general, 113 works well for OpenVMS™ systems with a transfer size of 8 sectors.

To calculate the chunk size that should be used for your subsystem, you must first analyze the types of requests that are being made to the subsystem:

- Many parallel I/Os that use a small area of disk should use a chunk size of 10 times the average transfer request rate.
- Random I/Os that are scattered over all the areas of the disks should use a chunk size of 20 times the average transfer request rate.
- If you do not know, then you should use a chunk size of 15 times the average transfer request rate.
- If you have mostly sequential reads or writes (like those needed to work with large graphic files), make the chunk size for RAID 0 and RAID 0+1 a small number (for example: 67 sectors). For RAID 5, make the chunk size a relatively large number (for example: 253 sectors).

Table 2-2 shows a few examples of chunk size selection.

Transfer Size (KB)	Small Area of I/O Transfers	Unknown	Random Areas of I/O Transfers
2	41	59	79
4	79	113	163
8	157	239	317

Increasing Sequential Data Transfer Performance

RAID 0 and RAID 0+1 sets intended for high data transfer rates should use a relatively low chunk size (for example: 67 sectors). RAID 5 sets intended for high data rate performance should use a relatively large number (for example: 253 sectors).

Save Configuration

The *SAVE CONFIGURATION* switch is for a single-controller configuration only. This switch reserves an area on each of the disks that constitutes the container being initialized. The controller can write subsystem configuration data on this area. If the controller is replaced, the new controller can read the subsystem configuration from the reserved areas of disks.

If you specify *SAVE_CONFIGURATION* for a multi-device storageset, such as a stripeset, the complete subsystem configuration is periodically written on each disk in the storageset.

The *SHOW DEVICES FULL* command shows which disks are used to backup configuration information.

Destroy/Nodestroy

Specify whether to destroy or retain the user data and metadata when a disk is initialized after it has been used in a mirrorset or as a single-disk unit.

NOTE: The *DESTROY* and *NODESTROY* switches are only valid for mirrorsets and striped mirrorsets.

- *DESTROY* (default) overwrites the user data and forced-error metadata when a disk drive is initialized.
- *NODESTROY* preserves the user data and forced-error metadata when a disk drive is initialized. Use *NODESTROY* to create a single-disk unit from any disk drive that has been used as a member of a mirrorset. See the *REDUCED* command in the *Compaq StorageWorks HSG80 Array Controller ACS Version 8.6 CLI Reference Guide* for information on removing disk drives from a mirrorset.

NODESTROY is ignored for members of a RAIDset.

Geometry

The geometry parameters of a storageset can be specified. The geometry switches are:

- *CAPACITY*—the number of logical blocks. The range is from 1 to the maximum container size.
- *CYLINDERS*—the number of cylinders used. The range is from 1 to 16777215.
- *HEADS*—the number of disk heads used. The range is from 1 to 255.

- *SECTORS_PER_TRACK*—the number of sectors per track used. The range is from 1 to 255.

Unit Switches

Several switches control the characteristics of units. The unit switches are described under the SET *unit-number* command in the *Compaq StorageWorks HSG80 Array Controller ACS Version 8.6 CLI Reference Guide*.

One unit switch, *ENABLE/DISABLE_ACCESS_PATH*, determines which host connections can access the unit, and is part of the larger topic of matching units to specific hosts. This complex topic is covered in Chapter 1 under the following headings:

- “Assigning Unit Numbers,” page 1–11
- “Assigning Unit Identifiers,” page 1–14

Storage Maps

Configuring a subsystem will be easier if you know how the storagesets, partitions, and JBODs correspond to the disk drives in your subsystem. You can more easily see this relationship by creating a hardcopy representation (a storage map).

Creating a Storage Map

To make a storage map, fill out the templates provided in Appendix A as you add storagesets, partitions, and JBOD disks to the configuration and assign them unit numbers. Label each disk drive in the map with the higher levels it is associated with, up to the unit level.

Example Storage Map - Model 4310R Disk Enclosure

Figure 2-19 shows an example of four Model 4310R disk enclosures (single-bus I/O).

- Unit D100 is a 4-member RAID 3/5 storageset named R1. R1 consists of Disk10000, Disk20000, Disk30000, and Disk40000.
- Unit D101 is a 2-member striped mirrorset named S1. S1 consists of M1 and M2:
 - M1 is a 2-member mirrorset consisting of Disk10100 and Disk20100.
 - M2 is a 2-member mirrorset consisting of Disk30100 and Disk40100.
- Unit D102 is a 2-member mirrorset named M3. M3 consists of Disk10200 and Disk20200.
- Unit D103 is a 2-member mirrorset named M4. M4 consists of Disk30200 and Disk40200.
- Unit D104 is 3-member stripeset named S2. S2 consists of Disk10300, Disk20300, and Disk30300.
- Unit D105 is a single (JBOD) disk named Disk40300.
- Unit D106 is a 3-member RAID 3/5 storageset named R2. R2 consists of Disk10400, Disk20400, and Disk30400.
- Unit D107 is a single (JBOD) disk named Disk40400.
- Unit D108 is a 4-member stripeset named S3. S3 consists of Disk10500, Disk20500, Disk30500, and Disk40500.
- Unit D1 is a 2-member striped mirrorset named S4. S4 consists of M4 and M5:
 - M5 is a 2-member mirrorset consisting of Disk10800 and Disk20800.
 - M6 is a 2-member mirrorset consisting of Disk30800 and Disk40800.
- Unit D2 is a 4-member RAID 3/5 storageset named R3. R3 consists of Disk11000, Disk21000, Disk31000, and Disk41000.
- Unit D3 is a 4-member stripeset named S5. S5 consists of Disk11100, Disk21100, Disk31100, and Disk41100.
- Unit D4 is a 2-member mirrorset named M7. M7 consists of Disk11200 and Disk21200.
- Disk31200 and Disk41200 are spareset members.

Model 4310R Disk Enclosure Shelf 4 (single-bus)

Bay	1	2	3	4	5	6	7	8	9	10
SCSI ID	00	01	02	03	04	05	08	10	11	12
DISK ID	D100 R1 Disk40000	D101 S1 M2 Disk40100	D103 M4 Disk40200	D105 Disk40300	D107 Disk40400	D108 S3 Disk40500	D1 S4 M6 Disk40800	D2 R3 Disk41000	D3 S5 Disk41100	spare Disk41200

Model 4310R Disk Enclosure Shelf 1 (single-bus)

Bay	1	2	3	4	5	6	7	8	9	10
SCSI ID	00	01	02	03	04	05	08	10	11	12
DISK ID	D100 R1 Disk10000	D101 S1 M1 Disk10100	D102 M3 Disk10200	D104 S2 Disk10300	D106 R2 Disk10400	D108 S3 Disk10500	D1 S4 M5 Disk10800	D2 R3 Disk11000	D3 S5 Disk11100	D4 M7 Disk11200

Model 4310R Disk Enclosure Shelf 2 (single-bus)

Bay	1	2	3	4	5	6	7	8	9	10
SCSI ID	00	01	02	03	04	05	08	10	11	12
DISK ID	D100 R1 Disk20000	D101 S1 M1 Disk20100	D102 M3 Disk20200	D104 S2 Disk20300	D106 R2 Disk20400	D108 S3 Disk20500	D1 S4 M5 Disk20800	D2 R3 Disk21000	D3 S5 Disk21100	D4 M7 Disk21200

Model 4310R Disk Enclosure Shelf 3 (single-bus)

Bay	1	2	3	4	5	6	7	8	9	10
SCSI ID	00	01	02	03	04	05	08	10	11	12
DISK ID	D100 R1 Disk30000	D101 S1 M2 Disk30100	D103 M4 Disk30200	D104 S2 Disk30300	D106 R2 Disk30400	D108 S3 Disk30500	D1 S4 M6 Disk30800	D2 R3 Disk31000	D3 S5 Disk31100	spare Disk31200

Figure 2-19. Model 4310R disk enclosure – example storage map

Example Storage Map - Model 4350R Disk Enclosure

Figure 2-20 shows an example of three Model 4350R disk enclosures (dual-bus).

- Unit D100 is a 6-member RAID 3/5 storage set named R1. R1 consists of Disk10000, Disk20000, Disk30000, Disk40000, Disk50000, and Disk60000.
- Unit D101 is a 6-member RAID 3/5 storage set named R2. R2 consists of Disk10100, Disk20100, Disk30100, Disk40100, Disk50100, and Disk60100.
- Unit D102 is a 2-member striped mirror set named S1. S1 consists of M1 and M2:
 - M1 is a 2-member mirror set consisting of Disk10200 and Disk20200.
 - M2 is a 2-member mirror set consisting of Disk30200 and Disk40200.
- Unit D103 is a 2-member mirror set named M3. M3 consists of Disk50200 and Disk60200.
- Unit D1 is a 4-member stripe set named S2. S2 consists of Disk10300, Disk20300, Disk30300, and Disk40300.
- Unit D2 is a 2-member mirror set named M4. M4 consists of Disk50300 and Disk60300.
- Unit D3 is a 2-member striped mirror set named S3. S3 consists of M5 and M6:
 - M5 is a 2-member mirror set consisting of Disk10400 and Disk20400.
 - M6 is a 2-member mirror set consisting of Disk30400 and Disk40400.
- Unit D4 is a single (JBOD) disk named Disk50400.
- Disk60400 is a spare set member.

Model 4350R Disk Enclosure Shelf 1 (dual-bus)

	SCSI Bus A					SCSI Bus B				
Bay	1	2	3	4	5	6	7	8	9	10
SCSI ID	00	01	02	03	04	00	01	02	03	04
	D100 R1	D101 R2	D102 S1 M1	D1 S2	D3 S3 M5	D100 R1	D101 R2	D102 S1 M1	D1 S2	D3 S3 M5
DISK ID	Disk10000	Disk10100	Disk10200	Disk10300	Disk10400	Disk20000	Disk20100	Disk20200	Disk20300	Disk20400

Model 4350R Disk Enclosure Shelf 2 (dual-bus)

	SCSI Bus A					SCSI Bus B				
Bay	1	2	3	4	5	6	7	8	9	10
SCSI ID	00	01	02	03	04	00	01	02	03	04
	D100 R1	D101 R2	D102 S1 M2	D1 S2	D3 S3 M6	D100 R1	D101 R2	D102 S1 M2	D1 S2	D3 S3 M6
DISK ID	Disk30000	Disk30100	Disk30200	Disk30300	Disk30400	Disk40000	Disk40100	Disk40200	Disk40300	Disk40400

Model 4350R Disk Enclosure Shelf 3 (dual-bus)

	SCSI Bus A					SCSI Bus B				
Bay	1	2	3	4	5	6	7	8	9	10
SCSI ID	00	01	02	03	04	00	01	02	03	04
	D100 R1	D101 R2	D103 M3	D2 M4	D4	D100 R1	D101 R2	D103 M3	D2 M4	spare
DISK ID	Disk50000	Disk50100	Disk50200	Disk50300	Disk50400	Disk60000	Disk60100	Disk60200	Disk60300	Disk60400

Figure 2-20. Model 4350R disk enclosure – example storage map

Example Storage Map - Model 4314R Disk Enclosure

Figure 2-21 shows an example of four Model 4314R disk enclosures (single-bus I/O).

- Unit D100 is a 4-member RAID 3/5 storageset named R1. R1 consists of Disk10000, Disk20000, Disk30000, and Disk40000.

- Unit D101 is a 2-member striped mirrorset named S1. S1 consists of M1 and M2:
 - M1 is a 2-member mirrorset consisting of Disk10100 and Disk20100.
 - M2 is a 2-member mirrorset consisting of Disk30100 and Disk40100.
- Unit D102 is a 2-member mirrorset named M3. M3 consists of Disk10200 and Disk20200.
- Unit D103 is a 2-member mirrorset named M4. M4 consists of Disk30200 and Disk40200.
- Unit D104 is 3-member stripeset named S2. S2 consists of Disk10300, Disk20300, and Disk30300.
- Unit D105 is a single (JBOD) disk named Disk40300.
- Unit D106 is a 3-member RAID 3/5 storage set named R2. R2 consists of Disk10400, Disk20400, and Disk30400.
- Unit D107 is a single (JBOD) disk named Disk40400.
- Unit D108 is a 4-member stripeset named S3. S3 consists of Disk10500, Disk20500, Disk30500, and Disk40500.
- Unit D1 is a 2-member striped mirrorset named S4. S4 consists of M5 and M6:
 - M5 is a 2-member mirrorset consisting of Disk10800 and Disk20800.
 - M6 is a 2-member mirrorset consisting of Disk30800 and Disk40800.
- Unit D2 is a 4-member RAID 3/5 storage set named R3. R3 consists of Disk10900, Disk20900, Disk30900, and Disk40900.
- Unit D3 is a 4-member stripeset named S5. S5 consists of Disk11000, Disk21000, Disk31000, and Disk41000.
- Unit D4 is a 2-member mirrorset named M7. M7 consists of Disk11100 and Disk21100.
- Unit D5 is a 2-member stripeset named S6. S6 consists of Disk31100 and Disk41100.
- Unit D6 is a 4-member RAID 3/5 storage set named R4. R4 consists of Disk11200, Disk21200, Disk31200, and Disk41200.
- Unit D7 is a 2-member mirrorset named M8. M8 consists of Disk11300 and Disk21300.
- Unit D8 is a 2-member stripeset named S7. S7 consists of Disk31300 and Disk41300.
- Unit D9 is a 4-member Raidset named R5. R5 consists of Disk41400, Disk11400, Disk21400 and Disk31400.
- Disk11500, Disk21500, Disk31500, and Disk41500 are spareset members.

Model 4314R Disk Enclosure Shelf 4 (single-bus)

Bay	1	2	3	4	5	6	7	8	9	10	11	12	13	14
SCSI ID	00	01	02	03	04	05	08	09	10	11	12	13	14	15
	D100 R1	D101 S1 M2	D103 M4	D105	D107	D108 S3	D1 S4 M6	D2 R3	D3 S5	D5 S6	D6 R4	D8 S7	D9 R5	spare
DISK ID	Disk40000	Disk40100	Disk40200	Disk40300	Disk40400	Disk40500	Disk40800	Disk40900	Disk41000	Disk41100	Disk41200	Disk41300	Disk41400	Disk41500

Model 4314R Disk Enclosure Shelf 1 (single-bus)

Bay	1	2	3	4	5	6	7	8	9	10	11	12	13	14
SCSI ID	00	01	02	03	04	05	08	09	10	11	12	13	14	15
	D100 R1	D101 S1 M1	D102 M3	D104 S2	D106 R2	D108 S3	D1 S4 M5	D2 R3	D3 S5	D4 M7	D6 R4	D7 M8	D9 R5	spare
DISK ID	Disk10000	Disk10100	Disk10200	Disk10300	Disk10400	Disk10500	Disk10800	Disk10900	Disk11000	Disk11100	Disk11200	Disk11300	Disk11400	Disk11500

Model 4314R Disk Enclosure Shelf 2 (single-bus)

Bay	1	2	3	4	5	6	7	8	9	10	11	12	13	14
SCSI ID	00	01	02	03	04	05	08	09	10	11	12	13	14	15
	D100 R1	D101 S1 M1	D102 M3	D104 S2	D106 R2	D108 S3	D1 S4 M5	D2 R3	D3 S5	D4 M7	D6 R4	D7 M8	D9 R5	spare
DISK ID	Disk20000	Disk20100	Disk20200	Disk20300	Disk20400	Disk20500	Disk20800	Disk20900	Disk21000	Disk21100	Disk21200	Disk21300	Disk21400	Disk21500

Model 4314R Disk Enclosure Shelf 3 (single-bus)

Bay	1	2	3	4	5	6	7	8	9	10	11	12	13	14
SCSI ID	00	01	02	03	04	05	08	09	10	11	12	13	14	15
	D100 R1	D101 S1 M2	D103 M4	D104 S2	D106 R2	D108 S3	D1 S4 M6	D2 R3	D3 S5	D5 S6	D6 R4	D8 S7	D9 R5	spare
DISK ID	Disk30000	Disk30100	Disk30200	Disk30300	Disk30400	Disk30500	Disk30800	Disk30900	Disk31000	Disk31100	Disk31200	Disk31300	Disk31400	Disk31500

Figure 2-21. Model 4314R disk enclosure – example storage map

Example Storage Map - Model 4354R Disk Enclosure

Figure 2-22 shows an example of three Model 4354R disk enclosures (dual-bus).

- Unit D100 is a 6-member RAID 3/5 storage set named R1. R1 consists of Disk10000, Disk20000, Disk30000, Disk40000, Disk50000, and Disk60000.
- Unit D101 is a 6-member RAID 3/5 storage set named R2. R2 consists of Disk10100, Disk20100, Disk30100, Disk40100, Disk50100, and Disk60100.
- Unit D102 is a 2-member striped mirror set named S1. S1 consists of M1 and M2:
 - M1 is a 2-member mirror set consisting of Disk10200 and Disk20200.
 - M2 is a 2-member mirror set consisting of Disk30200 and Disk40200.
- Unit D103 is a 2-member mirror set named M3. M3 consists of Disk50200 and Disk60200.
- Unit D104 is a 2-member striped mirror set named S2. S2 consists of M3 and M4:
 - M3 is a 2-member mirror set consisting of Disk10300 and Disk20300.
 - M4 is a 2-member mirror set consisting of Disk30300 and Disk40300.
- Unit D105 is a 2-member stripe set named S3. S3 consists of Disk50300 and Disk60300.
- Unit D1 is a 4-member stripe set named S4. S4 consists of Disk10400, Disk20400, Disk30400, and Disk40400.
- Unit D2 is a 2-member mirror set named M5. M5 consists of Disk50400 and Disk60400.
- Unit D3 is a 2-member striped mirror set named S5. S5 consists of M6 and M7:
 - M6 is a 3-member mirror set consisting of Disk10500, Disk20500, and Disk30500.
 - M7 is a 2-member mirror set consisting of Disk40500 and Disk50500.
- Unit D4 is a single (JBOD) disk named Disk60500.
- Unit D5 is a 4-member RAID 3/5 storage set named R3. R3 consists of Disk10800, Disk20800, Disk30800, and Disk40800.
- Disk50800 and Disk60800 are spare set members.

Model 4354R Disk Enclosure Shelf 1 (dual-bus)

	SCSI Bus A							SCSI Bus B						
Bay	1	2	3	4	5	6	7	8	9	10	11	12	13	14
SCSI ID	00	01	02	03	04	05	08	00	01	02	03	04	05	08
	D100 R1	D101 R2	D102 S1 M1	D104 S2 M3	D1 S4	D3 S5 M6	D5 R3	D100 R1	D101 R2	D102 S1 M1	D104 S2 M3	D1 S4	D3 S5 M6	D5 R3
DISK ID	Disk10000	Disk10100	Disk10200	Disk10300	Disk10400	Disk10500	Disk10800	Disk20000	Disk20100	Disk20200	Disk20300	Disk20400	Disk20500	Disk20800

Model 4354R Disk Enclosure Shelf 2 (dual-bus)

	SCSI Bus A							SCSI Bus B						
Bay	1	2	3	4	5	6	7	8	9	10	11	12	13	14
SCSI ID	00	01	02	03	04	05	08	00	01	02	03	04	05	08
	D100 R1	D101 R2	D102 S1 M2	D104 S2 M4	D1 S4	D3 S5 M6	D5 R3	D100 R1	D101 R2	D102 S1 M2	D104 S2 M4	D1 S4	D3 S5 M7	D5 R3
DISK ID	Disk30000	Disk30100	Disk30200	Disk30300	Disk30400	Disk30500	Disk30800	Disk40000	Disk40100	Disk40200	Disk40300	Disk40400	Disk40500	Disk40800

Model 4354R Disk Enclosure Shelf 3 (dual-bus)

	SCSI Bus A							SCSI Bus B						
Bay	1	2	3	4	5	6	7	8	9	10	11	12	13	14
SCSI ID	00	01	02	03	04	05	08	00	01	02	03	04	05	08
	D100 R1	D101 R2	D103 M3	D105 S3	D2 M5	D3 S5 M7	spare	D100 R1	D112 R2	D103 M3	D105 S3	D2 M5	D4	spare
DISK ID	Disk50000	Disk50100	Disk50200	Disk50300	Disk50400	Disk50500	Disk50800	Disk60000	Disk60100	Disk60200	Disk60300	Disk60400	Disk60500	Disk60800

Figure 2-22. Model 4354R disk enclosure – example storage map

Using the LOCATE Command to Find Devices

If you want to complete a storage map at a later time but do not remember where all disk drives, partitions, etc. are located, use the CLI command `LOCATE`. The `LOCATE` command flashes the (fault) LED on the drives associated with the specific storage set or unit. To turn off the flashing LEDs, enter the CLI command `LOCATE CANCEL`.

The following procedure is an example of the commands to locate all the disk drives that make up unit D104:

1. Enter the following command:

```
LOCATE D104
```

The LEDs on the disk drives that make up unit D104 will flash.

2. Note the position of all the drives contained within D104.
3. Enter the following command to turn off the flashing LEDs:

```
LOCATE CANCEL
```

The following procedure is an example command to locate all the drives that make up RAIDset R1:

1. Enter the following command:

```
LOCATE R1
```

2. Note the position of all the drives contained within R1.
3. Enter the following command to turn off the flashing LEDs:

```
LOCATE CANCEL
```

Chapter 3

Preparing the Host System

This chapter describes how to prepare your OpenVMS host computer to accommodate the HSG80 controller storage subsystem.

The following information is included in this chapter:

- “Enterprise Storage RAID Array Storage System Installation,” page 3–1
- “Making a Physical Connection,” page 3–5
- “Verifying/Installing Required Versions,” page 3–5

Enterprise Storage RAID Array Storage System Installation



WARNING: A shock hazard exists at the backplane when the controller enclosure bays or cache module bays are empty.

Be sure the enclosures are empty, then mount the enclosures into the rack. DO NOT use the disk enclosure handles to lift the enclosure. The handles cannot support the weight of the enclosure. Only use these handles to position the enclosure in the mounting brackets.

Use two people to lift, align, and install any enclosure into a rack. Failure to use two people might cause personal injury and/or equipment damage.



CAUTION: Controller and disk enclosures have no power switches. Make sure the controller enclosures and disk enclosures are physically configured before turning the PDU on and connecting the power cords. Failure to do so can cause equipment damage.

1. Be sure the enclosures are empty before mounting them into the rack. If necessary, remove the following elements from the controller enclosure:

- Environmental Monitoring Unit (EMU)
- External Cache Batteries (ECBs)
- Power Supplies
- Fans

If necessary, remove the following elements from the disk enclosure:

- Power Supply/Blower Assemblies
- Environmental Monitoring Unit (EMU)
- Disk Drives
- I/O Modules

Refer to the *Compaq StorageWorks Model 2100 and 2200 UltraSCSI Controller User Guide*, *Compaq StorageWorks Enclosure 4200 Family LVD Disk Enclosure User Guide*, and *Compaq StorageWorks Enclosure 4300 Family LVD Disk Enclosure User Guide* for further information.

2. Install brackets onto the controller enclosure and disk enclosures. Using two people, mount the enclosures into the rack. Refer to the mounting kit documentation for further information.
3. Install the elements. Install the disk drives. Make sure you install blank panels in any unused bays.

NOTE: Fibre channel cabling information is shown to illustrate supported configurations. In a dual-bus disk enclosure configuration, disk enclosures 1, 2, and 3 are stacked below the controller enclosure—two SCSI Buses per enclosure (see Figure 3-1). In a single-bus disk enclosure configuration, disk enclosures 6, 5, and 4 are stacked above the controller enclosure and disk enclosures 1, 2, and 3 are stacked below the controller enclosure—one SCSI Bus per enclosure(see Figure 3-2).

4. Connect the six VHDCI UltraSCSI bus cables between the controller and disk enclosures as shown in Figure 3-1 for a dual bus system and Figure 3-2 for a single bus system. Note that the supported cable lengths are 1, 2, 3, 5, and 10 meters.

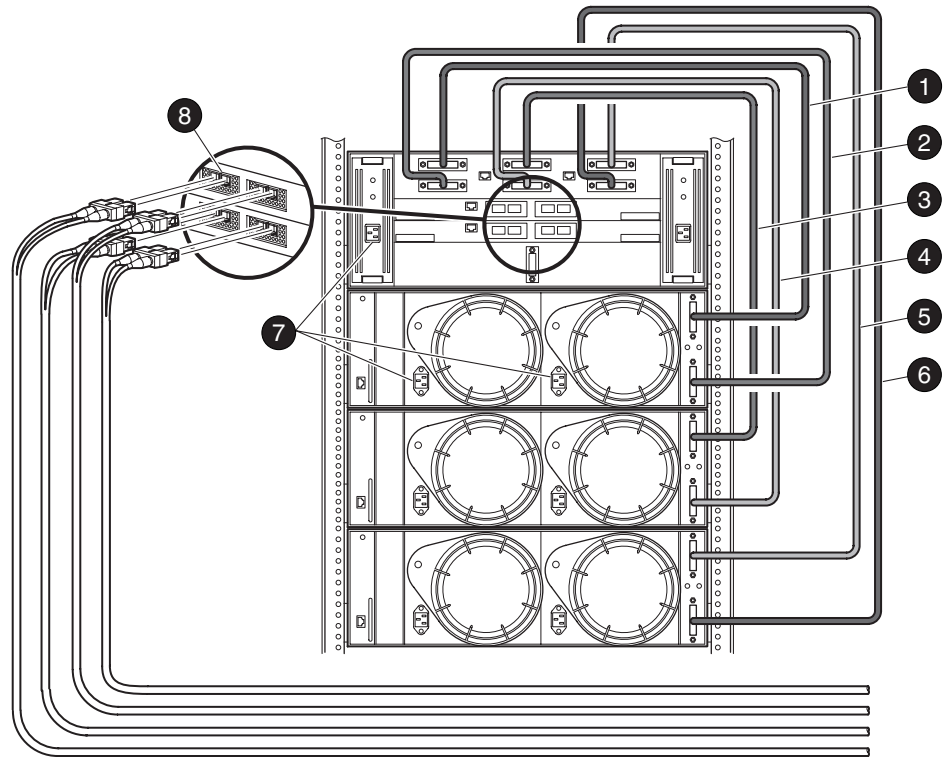

CXO7383A

- | | |
|--------------------|-----------------------|
| ❶ SCSI Bus 1 Cable | ❷ SCSI Bus 2 Cable |
| ❸ SCSI Bus 3 Cable | ❹ SCSI Bus 4 Cable |
| ❺ SCSI Bus 5 Cable | ❻ SCSI Bus 6 Cable |
| ❽ AC Power Inputs | ❿ Fibre Channel Ports |

Figure 3-1. Dual-Bus Enterprise Storage RAID Array Storage System

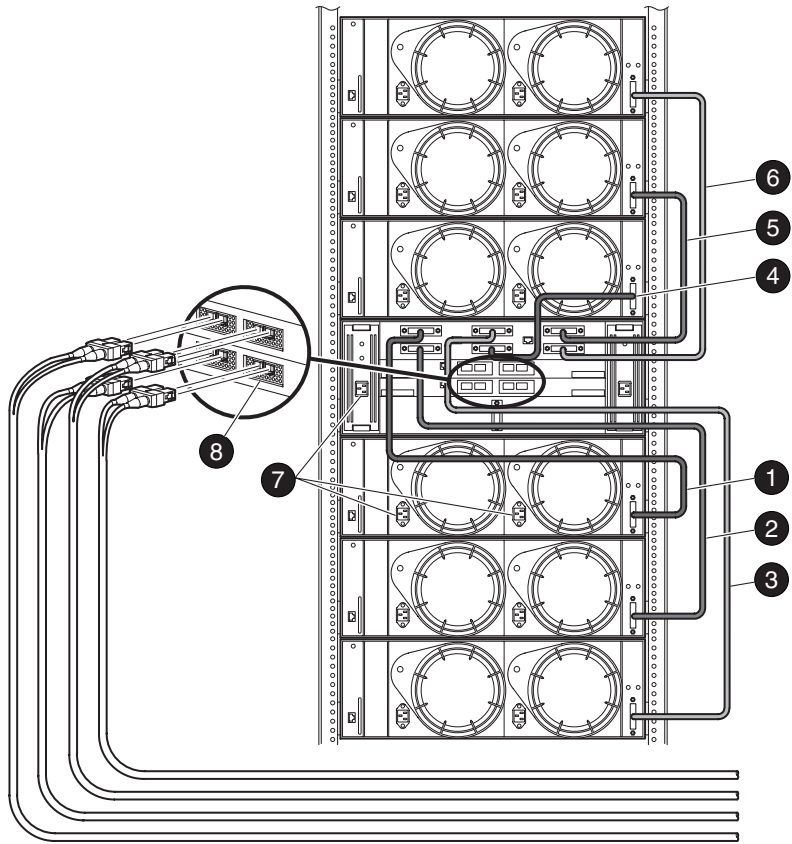

CXO7382A

- | | |
|--------------------|-----------------------|
| ❶ SCSI Bus 1 Cable | ❷ SCSI Bus 2 Cable |
| ❸ SCSI Bus 3 Cable | ❹ SCSI Bus 4 Cable |
| ❺ SCSI Bus 5 Cable | ❻ SCSI Bus 6 Cable |
| ❼ AC Power Inputs | ❽ Fibre Channel Ports |

Figure 3-2. Single-Bus Enterprise Storage RAID Array Storage System

5. Connect the AC power cords from the appropriate rack AC outlets to the controller and disk enclosures.

Making a Physical Connection

To attach a host computer to the storage subsystem, install one or more host bus adapters into the computer. A Fibre Channel (FC) cable goes from the host bus adapter to a FC switch .

Preparing to Install the Host Bus Adapter

Before installing the host bus adapter, perform the following steps:

1. Perform a complete backup of the entire system.
2. Shut down the computer system.

Installing the Host Bus Adapter

The first step in making a physical connection is the installation of a host bus adapter.



CAUTION: Protect the host bus adapter board from electrostatic discharge by wearing an ESD wriststrap. DO NOT remove the board from the antistatic cover until you are ready to install it.

You need the following items to begin:

- Host bus adapter board
- The computer hardware manual
- Appropriate tools to service your computer

The host bus adapter board plugs into a standard PCI slot in the host computer. Refer to the system manual for instructions on installing PCI devices.

NOTE: Do not power on anything yet. For the FC switches to autoconfigure, power on equipment in a certain sequence. Also, the controllers in the subsystem are not yet configured for compatibility with OpenVMS.

Verifying/Installing Required Versions

Compatibility with the HSG80 controller requires that the host run OpenVMS Version 7.2-1 at minimum with the following Remedial Kits:

DEC-AXPVMS-VMS721_PCSI-V0100—4.PCSI

DEC-AXPVMS-VMS721_UPDATE-V0100--4.PCSI

DEC-AXPVMS-VMS721_FIBRE_SCSI-V0400-44.PCSI

DEC-AXPVMS-VMS721_SYS-V0900--4.PCSI

The Remedial Kits can be obtained at the following website:

<http://ftp.support.compaq.com/public/vms/axp>

NOTE: The Remedial Kits at this website are self-expanding compressed files. The name of the compressed file will be kit_name-dcx_vaxexe for OpenVMS VAX or kit_name-dcx_apexe for OpenVMS Alpha.

Once the file is copied to your system, it can be expanded by using the RUN command. The resultant PCSI file can then be installed using the PRODUCT INSTALL command. Complete installation directions are included with each kit.

Installing and Configuring the HS-Series Agent

The following information is included in this chapter:

- “Why StorageWorks Command Console (SWCC)?,” page 4–1
- “Installation and Configuration Overview,” page 4–2
- “About the Network Connection for the Agent,” page 4–3
- “Reconfiguring the Agent,” page 4–10
- “Removing the Agent,” page 4–13

Why StorageWorks Command Console (SWCC)?

StorageWorks Command Console (SWCC) enables you to monitor and configure the storage connected to the HSG80 controller. SWCC consists of Client and Agent.

- Client provides pager notification and lets you manage your virtual disks. Client runs on Windows 2000 with Service Pack 1 and Windows NT 4.0 (Intel) with Service Pack 6A.
- Agent obtains the status of the storage connected to the controller. It also passes the status of the devices connected to the controller to other computers and provides email notification and error logging.

To receive information about the devices connected to your HSG80 controller over a TCP/IP network, you must install the Agent on a computer that is connected to a controller.

The Agent can also be used as a standalone application without Client. In this mode, which is referred to as Agent only, Agent monitors the status of the subsystem and provides local and remote notification in the event of a failure. A subsystem includes the HSG80 controller and its devices. Remote and local notification can be made by email and/or SNMP messages to an SNMP monitoring program.

Table 4-1 SWCC Features and Components

Features	Agent Required?	Client Required?
Able to create the following:	Yes	Yes
■ Striped device group (RAID 0)		
■ Mirrored device group (RAID 1)		
■ Striped mirrored device group (RAID 0+1)		
■ Striped parity device group (RAID 3/5)		
■ Individual device (JBOD)		
Able to monitor many subsystems at once	Yes	Yes
Event logging	Yes	No
Email notification	Yes	No
Pager notification	Yes	Yes

NOTE: For serial and SCSI connections, the Agent is not required for creating virtual disks.

Installation and Configuration Overview

Table 4-2 provides an overview of the installation.

Table 4-2 Installation and Configuration Overview

Step	Procedure
1	Verify that your hardware has been set up correctly. See the previous chapters in this guide.
2	Verify that you have a network connection for the Client and Agent systems. See “About the Network Connection for the Agent” on page 4-3.

Table 4-2 Installation and Configuration Overview

Step	Procedure
3	Verify that there is a LUN to communicate through. This can be either the CCL or a LUN that was created with the CLI. See "The Command Console LUN" described in Chapter 1.
4	Install the Agent (TCP/IP network connections) on a system connected to the HSG80 controller. See "Installing and Configuring the Agent," page 4-6.
5	Add the name of the Client system to the Agent's list of Client system entries (TCP/IP network connections). This can be done during installation or when reconfiguring the Agent.
6	Install the Client software on Windows 2000 with Service Pack 1 or Windows NT 4.0 (Intel) with Service Pack 6A. See Appendix B.
7	Add the name of the agent system to the Navigation Tree of each Client system that is on the Agent's list of Client system entries (TCP/IP network connections). See Appendix B.
8	Set up pager notification (TCP/IP network connections). Refer to "Setting Up Pager Notification" in the <i>Compaq StorageWorks Command Console Version 2.4 User Guide</i> .

About the Network Connection for the Agent

The network connection, shown in Figure 4-1, displays the subsystem connected to a hub or a switch. SWCC can consist of any number of Clients and Agents in a network. However, it is suggested that you install only one Agent (except for the HSZ22 Agent) on a computer.

By using a network connection, you can configure and monitor the subsystem from anywhere on the LAN. If you have a WAN or a connection to the Internet, monitor the subsystem with TCP/IP.

IMPORTANT: SWCC does not support the dynamic host configuration protocol (DHCP) or the Windows Internet Name Service (WINS).

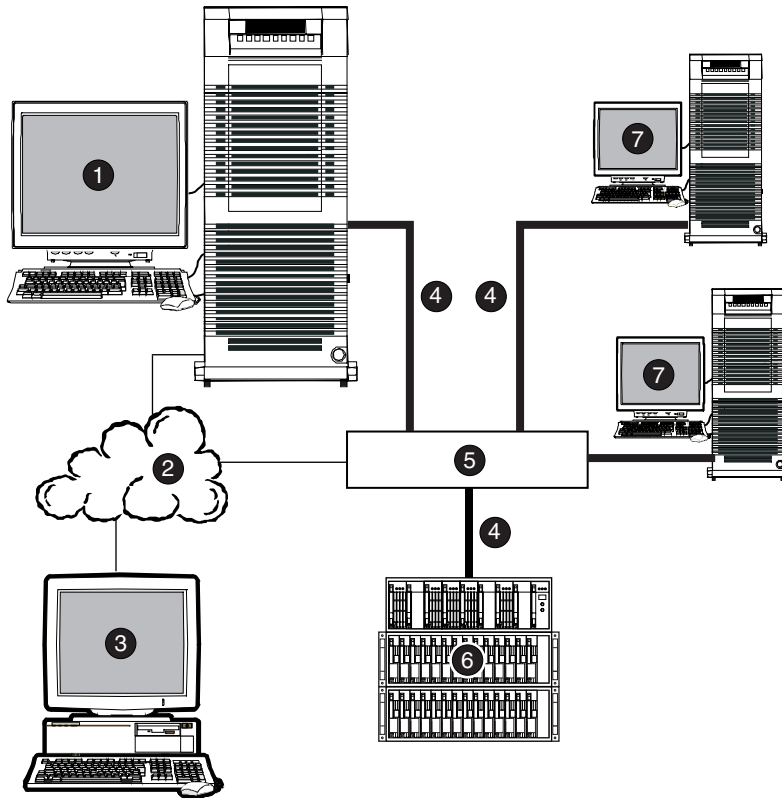

CXO7240A

Figure 4-1. An example of a network connection

- | | |
|---|---|
| ❶ Agent system (has the Agent software) | ❺ Hub or switch |
| ❷ TCP/IP Network | ❻ HSG80 controller and its device subsystem |
| ❸ Client system (has the Client software) | ❼ Servers |
| ❹ Fibre Channel cable | |

Options for Running the Agent

Agent runs as an OpenVMS process called “SWCC_AGENT.” You can use the Agent configuration program to control the execution of this process. You can:

- Immediately start or stop your Agent.
- Start your Agent automatically each time the host is started (This is the only mode available for TCPware and MultiNet).
- Start your Agent as an auxiliary service of TCP/IP Services for OpenVMS (default). It starts Agent on demand.

Before Installing the Agent

1. Verify that you have one of the following:
 - TCP/IP Services for OpenVMS (version 5.0 or later) with FTP and Telnet utilities enabled
 - TCPware (version 5.2 or later)
 - MultiNet TCP/IP for OpenVMS (version 4.0 or later)

Table 4-3 Minimum OpenVMS Host Requirements

Host Feature	Requirements
Architecture	Alpha server with 3000 blocks of free space on system disk
Operating System	OpenVMS version 7.2-1 with Remedial Kits installed

2. Your OpenVMS host's resources must meet the minimum requirements specified in Table 4-3.
3. Remove previous versions of the Agent from your computer.

If you are removing the Agent version 1.1b, delete the file, `change_register.com`, from the `SYS$SYSDEVICE:[SWCC$AGENT]` directory.
4. Read the release notes that are in the file, `HSG80VMS.TXT`.
5. If you have OpenVMS version 7.2-1 on an Alpha computer with MultiNet and/or TCPware TCP/IP stacks, you must install the security patch from the Process Software Website at <http://www.process.com>.
6. If you have an HSJ40 controller, check the controller firmware revision level. If your controller is at version 3.2J you must upgrade to version 3.4J before installing the Agent. This is due to an issue with the 3.2J firmware that causes controller hangs intermittently when used with the Agent.

Installing and Configuring the Agent

All Agent installations on OpenVMS must be done locally. Do not attempt to install the Agent over the network. Install the software on a system that is connected to the controller.

For the following examples, you can replace DKB600 and DKB100:[SWCC] with others more suitable for your system.

1. Insert the CD-ROM into the system that is connected to the controller.

For the examples in this section, assume the CD-ROM device is DKB600.

2. To mount the CD-ROM, enter the following at the command prompt (Replace DKB600 with the name of your CD-ROM device.):

```
$ MOUNT/OVER=ID/MEDIA=CD DKB600:
```

3. To create a local directory on your system, enter the following at the command prompt. Later in this procedure, you will copy the installation file from the CD-ROM to this new directory. Replace DKB100 with the name of your hard drive on the system that is connected to the controller.

```
$ CREATE/DIRECTORY DKB100:[SWCC]
```

A directory named DKB100:[SWCC] has been created.

4. To set the default directory, enter the following at the command prompt (Replace DKB100 with the name of your hard drive.):

```
$ SET DEFAULT DKB100:[SWCC]
```

5. Copy the self-extracting file from the CD-ROM to the default directory. Enter the following command (Replace DKB600 with the name of your CD-ROM drive):

```
$ COPY DKB600:[SWCC.AGENTS.VMS]SWCC24.EXE *.*
```

6. To expand the self-extracting file, enter the following:

```
$ RUN SSWCC24.EXE
```

7. To install the kit, enter the following at the command prompt:

```
$ PRODUCT INSTALL SWCC/SOURCE=[ ]
```

The system responds with a message that SWCC is the product selected to install. You are asked if you want to continue.

8. Press **Enter** to continue. An installation verification message appears. The last line of the message is the following:

```
To configure SWCC Agent for HS* controllers: @sys$manager:swcc_config
```

9. If you have an OpenVMS cluster running the MultiNet TCP/IP stack, the command procedure SWCC_CONFIG.COM will only upgrade the services of each system disk's first node. Enter the following to upgrade the services database of the other nodes that share the system disk:

```
$ @MULTINET:INSTALL_DATABASES
```

or

Restart the system.

10. Dismount the CD-ROM. Enter the following at the command prompt and then press **Enter** (The following example assumes that your CD-ROM drive is DKB600.):

```
$ DISMOUNT DKB600:
```

11. Run the configuration program. Enter the following at the command prompt:

```
$ @SYS$MANAGER:SWCC_CONFIG
```

If the installation does not detect any configuration files from a previous installation, you are shown a configuration script when you run the configuration program. During the configuration, you will need to do at least the following:

- Enter the name of the client system on which you installed the Client software. You can enter more than one client system. For a client system to receive updates from the Agent, it must be on the Agent's list of client system entries. In addition, adding a client system entry allows you to access the agent system from the Navigation Tree.

NOTE: Enter your most important client system first and the client system that is infrequently connected to the network last. The software will put the client system entry that you entered first to the top of its list of client systems to be contacted.

- Enter client system notification options and the client system access options. For a definition of the client system notification options and the client system access options, see Table 4-3.
- Enter the name for a subsystem and the device name used to access the subsystem. You can enter more than one subsystem. If you want to monitor and manage a subsystem, you need to enter this information. The subsystem, which is comprised of the controller and its array of physical devices, must have access to the Agent system.
- Enter a password. It must be a text string that has 4 to 16 characters. It is entered from the client system to gain configuration access.
- Start the Agent. The Agent runs as a process in the background. When you start the Agent, you are instructing the software to start monitoring the subsystems.

All Agent installations on OpenVMS must be done locally. Do not attempt to install the Agent over the network. Install the software on a system that is connected to the controller.

For the following examples, you can replace DKB600 and DKB100:[SWCC] with others more suitable for your system.

1. Insert the CD-ROM into the system that is connected to the controller.

For the examples in this section, assume the CD-ROM device is DKB600.

2. To mount the CD-ROM, enter the following at the command prompt (Replace DKB600 with the name of your CD-ROM device.):

```
$ MOUNT/OVER=ID/MEDIA=CD DKB600:
```

3. To create a local directory on your system, enter the following at the command prompt. Later in this procedure, you will copy the installation file from the CD-ROM to this new directory. Replace DKB100 with the name of your hard drive on the system that is connected to the controller.

```
$ CREATE/DIRECTORY DKB100:[SWCC]
```

A directory named DKB100:[SWCC] has been created.

4. To set the default directory, enter the following at the command prompt (Replace DKB100 with the name of your hard drive.):

```
$ SET DEFAULT DKB100:[SWCC]
```

5. Copy the self-extracting file from the CD-ROM to the default directory. Enter the following command (Replace DKB600 with the name of your CD-ROM drive):

```
$ COPY DKB600:[SWCC.AGENTS.VMS]SWCC24.EXE *.*
```

6. To expand the self-extracting file, enter the following:

```
$ RUN SSWCC24.EXE
```

7. To install the kit, enter the following at the command prompt:

```
$ PRODUCT INSTALL SWCC/SOURCE=[ ]
```

The system responds with a message that SWCC is the product selected to install. You are asked if you want to continue.

8. Press **Enter** to continue. An installation verification message appears. The last line of the message is the following:

```
To configure SWCC Agent for HS* controllers: @sys$manager:swcc_config
```

9. If you have an OpenVMS cluster running the MultiNet TCP/IP stack, the command procedure SWCC_CONFIG.COM will only upgrade the services of each system disk's first node. Enter the following to upgrade the services database of the other nodes that share the system disk:

```
$ @MULTINET:INSTALL_DATABASES
```

or

Restart the system.

10. Dismount the CD-ROM. Enter the following at the command prompt and then press **Enter** (The following example assumes that your CD-ROM drive is DKB600.):

```
$ DISMOUNT DKB600:
```

11. Run the configuration program. Enter the following at the command prompt:

```
$ @SYS$MANAGER:SWCC_CONFIG
```

If the installation does not detect any configuration files from a previous installation, you are shown a configuration script when you run the configuration program. During the configuration, you will need to do at least the following:

- Enter the name of the client system on which you installed the Client software. You can enter more than one client system. For a client system to receive updates from the Agent, it must be on the Agent's list of client system entries. In addition, adding a client system entry allows you to access the agent system from the Navigation Tree.

NOTE: Enter your most important client system first and the client system that is infrequently connected to the network last. The software will put the client system entry that you entered first to the top of its list of client systems to be contacted.

- Enter client system notification options and the client system access options. For a definition of the client system notification options and the client system access options, see Table 4-3.
- Enter the name for a subsystem and the device name used to access the subsystem. You can enter more than one subsystem. If you want to monitor and manage a subsystem, you need to enter this information. The subsystem, which is comprised of the controller and its array of physical devices, must have access to the Agent system.
- Enter a password. It must be a text string that has 4 to 16 characters. It is entered from the client system to gain configuration access.
- Start the Agent. The Agent runs as a process in the background. When you start the Agent, you are instructing the software to start monitoring the subsystems.

Reconfiguring the Agent

You can change your configuration using the SWCC Command Console Agent Configuration menu by entering the following command:

```
$ @sys$manager:swcc_config
```

The following is an example of the Agent Configuration menu:

```
SWCC Agent for HS* Controllers Configuration Menu  
Agent is enabled as TCP/IP Services for OpenVMS service.  
Agent is now: active  
Agent Admin Options:  
1)Change Agent password  
2)Agent Enable/Start  
3)Agent Disable/Stop  
4)Uninstall Agent  
Client Options:  
5)Add a Client  
6)Remove a Client  
7)View Clients  
Storage Subsystem Options:  
8)Add a subsystem  
9)Remove a subsystem  
10)View subsystems  
E)Exit configuration procedure
```



CAUTION: After you make a change to the configuration, such as adding a client system, you must stop and then start the Agent for your changes take effect. When you stop and then start the Agent, the Storage Windows for the subsystems connected to the agent system lose their connection. To regain that connection, close and then reopen the Storage Windows connected to the agent system after you restart the Agent.

Table 4-4 Information Needed to Configure Agent

Term/Procedure	Description
Adding a Client system entry	For a client system to receive updates from the Agent, you must add it to the Agent's list of client system entries. The Agent will only send information to client system entries that are on this list. In addition, adding a client system entry allows you to access the Agent system from the Navigation Tree on that Client system.
Adding a subsystem entry	You need to tell the Agent the subsystem that it needs to monitor.
Client system	Network names for the computers on which the Client software runs.
Client system access options	<p>The access privilege level controls the Client system's level of access to the subsystems.</p> <p>0=No Access—Can use the Client software to add a system to a Navigation Tree, set up a pager, and view properties of the controller and the system. You cannot use Client to open a Storage Window.</p> <p>1=Show Level Access—Can use the Client software to open a Storage Window, but you cannot make modifications in that window.</p> <p>2=Storage Subsystem Configuration Capability—Can use the Client software to make changes in a Storage Window to modify a subsystem configuration.</p>
Client system notification options Note: For all of the client system notification options, local notification is available through an entry in the system error log file and Email (provided that Email notification in PAGEMAIL.COM has not been disabled).	<p>0 = No Error Notification—No error notification is provided over network.</p> <p>1 = Notification via a TCP/IP Socket (Transmission Control Protocol/Internet Protocol)—Updates the Storage Window of subsystem changes provided AES is running. Required for Windows NT event logging and pager notification. If you do not select TCP/IP, you will need to refresh the Storage Window to obtain the latest status of a subsystem.</p> <p>2 = Notification via the SNMP protocol (Simple Network Management Protocol)—Requires you to use an SNMP-monitoring program to view SNMP traps.</p> <p>3 = Notification via both TCP/IP and SNMP—Combination of options 1 and 2.</p>

Table 4-4 Information Needed to Configure Agent (Continued)

Term/Procedure	Description
Deleting a client system entry	When you remove a client system from the Agent's list, you are instructing the Agent to stop sending updates to that client system. In addition, you will be unable to access this agent system from the Navigation Tree.
Email notification	<p>Modify file pagemail.com in directory sys\$manager. System is the default.</p> <p>When an error is logged, the Agent executes the PAGEMAIL.COM command. You can modify this file for Agent to log errors in a log file and/or change the account to which Agent sends messages. You can also modify for which level of errors you will be notified. Client does not need to be running to perform these actions.</p>
Monitoring interval in seconds	How often the subsystem is monitored.
Password	It must be a text string that has 4 to 16 characters. It can be entered from the client system to gain configuration access. Accessing the SWCC Agent Configuration menu can change it.

You can change your configuration using the SWCC Agent Configuration menu. To access this menu, enter the following command:

```
$ @sys$manager:swcc_config
```

The following is an example of the Agent Configuration menu:

SWCC Agent for HS* Controllers Configuration Menu
Agent is enabled as TCP/IP Services for OpenVMS service.
Agent is now: active
Agent Admin Options:
1)Change Agent password
2)Agent Enable/Start
3)Agent Disable/Stop
4)Uninstall Agent
Client Options:
5)Add a Client
6)Remove a Client

SWCC Agent for HS* Controllers Configuration Menu
7)View Clients
Storage Subsystem Options:
8)Add a subsystem
9)Remove a subsystem
10)View subsystems
E)Exit configuration procedure

Removing the Agent

Instructions on how to remove the HS-Series Agent from OpenVMS are the following:

CAUTION: Do not uninstall the Agent if you want to preserve configuration information. If you only want to install an upgrade, stop the Agent, and then install the new version. Older versions will be automatically removed before the update, but all configuration information will be preserved.

1. Enter the following at the command prompt:

```
$ @sys$manager:swcc_config
```

The Configuration menu appears.
2. To remove the Agent, select option **4**.
3. Select option **Y**. The host tells you that the Agent has been stopped and SWCC is being disabled. You are then asked if you want to continue.
4. Select option **Y**.

NOTE: This option does the following:

Stops all instances of the Agent on all cluster nodes

Deletes all Agent files, except the .PCSI file used to install the Agent.

Chapter 5

Configuration Procedures

This chapter describes procedures to configure a subsystem that uses Fibre Channel fabric topology. In fabric topology, the controller connects to its hosts through switches.

The following information is included in this chapter:

- “Establishing a Local Connection,” page 5–2
- “Setting Up a Single Controller,” page 5–3
- “Setting Up a Controller Pair,” page 5–9
- “Configuring Devices,” page 5–16
- “Configuring a Stripeset,” page 5–16
- “Configuring a Mirrorset,” page 5–16
- “Configuring a RAIDset,” page 5–17
- “Configuring a Striped Mirrorset,” page 5–18
- “Configuring a Single-Disk Unit (JBOD),” page 5–19
- “Configuring a Partition,” page 5–19
- “Assigning Unit Numbers and Unit Qualifiers,” page 5–20
- “Configuration Options,” page 5–23

Use the command line interpreter (CLI) or StorageWorks Command Console (SWCC) to configure the subsystem. This chapter uses CLI, which is the low-level interface to the controller. To use SWCC for configuration, see the SWCC online help for assistance.

IMPORTANT: These configuration procedures assume that controllers and cache modules are installed in a fully functional and populated enclosure and that the PCMCIA cards are installed.

To install a controller or cache module and the PCMCIA card, see the *Compaq StorageWorks HSG80 Array Controller ACS Version 8.6 Maintenance and Service Guide*.

Establishing a Local Connection

A local connection is required to configure the controller until a command console LUN (CCL) is established using the CLI. Communication with the controller can be through the CLI or SWCC.

The maintenance port, shown in Figure 5-1, provides a way to connect a maintenance terminal. The maintenance terminal can be an EIA-423 compatible terminal or a computer running a terminal emulator program. The maintenance port accepts a standard RS-232 jack. The maintenance port cable shown in Figure 5-1 has a 9-pin connector molded onto the end for a PC connection. If you need a terminal connection or a 25-pin connection, you can order optional cabling.

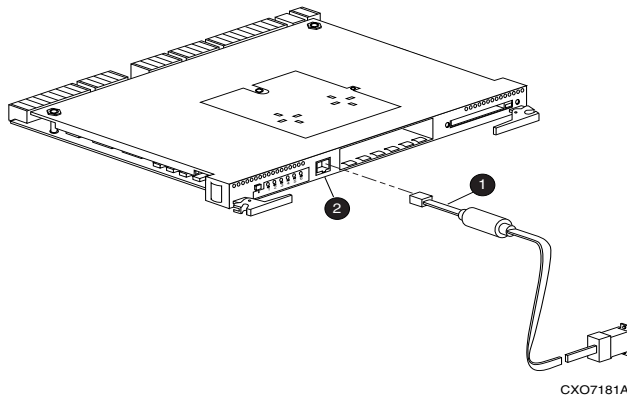

① Maintenance Port Cable

② Maintenance Port

Figure 5-1. Maintenance port connection



CAUTION: The maintenance port generates, uses, and can radiate radio-frequency energy through its cables. This energy may interfere with radio and television reception. Disconnect all maintenance port cables when not communicating with the controller through the local connection.

Setting Up a Single Controller

Power On and Establish Communication

1. Connect the computer or terminal to the controller as shown in Figure 5-1. The connection to the computer is through the COM1 or COM2 port.
2. Turn on the computer or terminal.
3. Apply power to the storage subsystem.
4. Verify that the computer or terminal is configured as follows:
 - 9600 baud
 - 8 data bits
 - 1 stop bit
 - no parity
5. Press **Enter**. A copyright notice and the CLI prompt appear, indicating that you established a local connection with the controller.

Cabling a Single Controller

The cabling for a single controller is shown in Figure 5-2.

NOTE: It is a good idea to plug only the controller cables into the switch. The host cables are plugged into the switch as part of the configuration procedure (“Configuring a Single Controller Using CLI,” page 5-4).

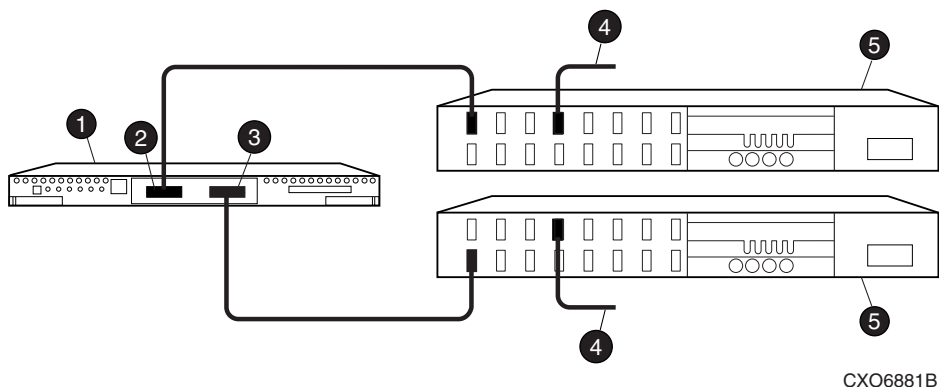

- ❶ Controller
- ❷ Host port 1
- ❸ Host port 2
- ❹ Cable from the switch to the host Fibre Channel adapter
- ❺ FC switch

Figure 5-2. Single controller cabling

Configuring a Single Controller Using CLI

To configure a single controller using CLI involves the following processes:

- Verify the Node ID and Check for Any Previous Connections.
- Configure Controller Settings.
- Restart the Controller.
- Set Time and Verify all Commands.
- Plug in the FC Cable and Verify Connections.
- Repeat Procedure for Each Host Adapter.
- Verify Installation.

Verify the Node ID and Check for Any Previous Connections

1. Enter a SHOW THIS command to verify the node ID:
SHOW THIS

See “Worldwide Names (Node IDs and Port IDs),” page 1–18, for the location of the sticker.

The node ID is located in the third line of the SHOW THIS result:

```
HSG80> SHOW THIS
```

Controller:

```
HSG80 ZG80900583 Software V8.6F-1, Hardware E11
NODE_ID      = 5000-1FE1-0001-3F00
ALLOCATION_CLASS = 0
```

If the node ID is present, go to step 5.

If the node ID is all zeroes, enter the node ID and checksum, which are located on a sticker on the controller enclosure. Use the following syntax to enter the node ID:

```
SET THIS NODE_ID=NNNN-NNNN-NNNN-NNNN nn
```

Where:*NNNN-NNNN-NNNN-NNNN* is the node ID, and *nn* is the checksum.

2. When using a controller that is not new from the factory, enter the following command to take it out of any failover mode that may have been configured previously:

```
SET NOFAILOVER
```

If the controller did have a failover mode previously set, the CLI may report an error. Clear the error with this command:

```
CLEAR_ERRORS CLI
```

3. Enter the following command to remove any previously configured connections:

```
SHOW CONNECTIONS
```

A list of named connections, if any, is displayed.

4. Delete these connections by entering the following command:

```
DELETE !NEWCON01
```

Repeat the Delete command for each of the listed connections. When completed, no connections will be displayed.

Configure Controller Settings

5. Set the SCSI version to SCSI-3 using the following command:

```
SET THIS SCSI_VERSION=SCSI-3
```

NOTE: Setting the SCSI version to SCSI-3 does not make the controller fully compliant with the SCSI-3 standards.

```
SET THIS SCSI_VERSION=SCSI-3
```

NOTE: Setting the SCSI version to SCSI-3 does not make the controller fully compliant with all SCSI-3 standards. .

6. Assign an identifier for the communication LUN (also called the command console LUN, or CCL). The CCL must have a unique identifier that is a decimal number in the range 1 to 32767, and which is different from the identifiers of all units. Use the following syntax:

```
SET THIS IDENTIFIER=N
```

Identifier must be unique among all the controllers attached to the fabric within the specified allocation class.

7. Set the topology for the controller. If both ports are used, set topology for both ports:

```
SET THIS PORT_1_TOPOLOGY=FABRIC
```

```
SET THIS PORT_2_TOPOLOGY=FABRIC
```

If the controller is not factory-new, it may have another topology set, in which case these commands will result in an error message. If this happens, take both ports offline first, then reset the topology:

```
SET THIS PORT_1_TOPOLOGY=OFFLINE
```

```
SET THIS PORT_2_TOPOLOGY=OFFLINE
```

```
SET THIS PORT_1_TOPOLOGY=FABRIC
```

```
SET THIS PORT_2_TOPOLOGY=FABRIC
```

8. Set Allocation class to a decimal number between 0 and 999. The number must be unique across the fabric. Set allocation class using the following syntax:

```
SET THIS ALLOCATION_CLASS=N
```

Restart the Controller

9. Restart the controller, using the following command:

```
RESTART THIS
```

10. Assign an identifier for the communication LUN (also called the command console LUN, or CCL). The CCL must have a unique identifier that is a decimal number in the range 1 to 32767, and which is different from the identifiers of all units. Use the following syntax:

```
SET THIS IDENTIFIER=N
```

Identifier must be unique among all the controllers attached to the fabric within the specified allocation class.

Set Time and Verify all Commands

11. Set the time on the controller by entering the following syntax:

```
SET THIS TIME=DD-MMM-YYYY:HH:MM:SS
```

12. Use the FRUTIL utility to set up the battery discharge timer. Enter the following command to start FRUTIL:

```
RUN FRUTIL
```

When FRUTIL asks if you intend to replace the battery, answer “**Y**”:

```
Do you intend to replace this controller's cache battery? Y/N [N] Y
```

FRUTIL will print out a procedure, but will not give you a prompt. Ignore the procedure and press the **Enter** key.

13. Set up any additional optional controller settings, such as changing the CLI prompt. See the `SET THIS CONTROLLER/OTHER CONTROLLER` command in the *Compaq StorageWorks HSG80 Array Controller ACS Version 8.6 CLI Reference Guide* for the format of optional settings.

14. Verify that all commands have taken effect. Use the following command:

```
SHOW THIS
```

Verify node ID, allocation class, SCSI version, failover mode, identifier, and port topology.

The following sample is a result of a SHOW THIS command, with the areas of interest in bold.

Controller:

HSG80 (C) DEC ZG09030200 Software V8.6F, Hardware 0000

NODE_ID = 5000-1FE1-0000-0000

ALLOCATION_CLASS = 1

SCSI_VERSION = SCSI-3

Not configured for dual-redundancy

Device Port SCSI address 7

Time: 10-Mar-1999:12:30:34

Command Console LUN is lun 0 (IDENTIFIER = 88)

Host PORT_1:

Reported PORT_ID = 5000-1FE1-0000-0001

PORT_1_TOPOLOGY = FABRIC (fabric up)

Address = 210313

Host PORT_2:

Reported PORT_ID = 5000-1FE1-0000-0002

PORT_2_TOPOLOGY = FABRIC (fabric up)

Address = 210513

NOREMOTE_COPY

.....

15. Turn on the switches, if not done previously.

If you want to communicate with the Fibre Channel switches through Telnet, set an IP address for each switch. See the manuals that came with the switches for details.

Plug in the FC Cable and Verify Connections

16. Plug the Fibre Channel cable from the first host bus adapter into the switch. Enter the SHOW CONNECTIONS command to view the connection table:

```
SHOW CONNECTIONS
```

17. Rename the connections to something meaningful to the system and easy to remember. For example, to assign the name ANGEL1A1 to connection !NEWCON01, enter:

```
RENAME !NEWCON01 ANGEL1A1
```

For a recommended naming convention, see “Naming Connections,” page 1-9.

18. Specify the operating system for the connection:

```
SET ANGEL1A1 OPERATING_SYSTEM=VMS
```

19. Verify the changes:

```
SHOW CONNECTIONS
```

Mark or tag all Fibre Channel cables at both ends for ease of maintenance.

Repeat Procedure for Each Host Adapter

20. Repeat step 17, 18, and 19 for each of that adapter’s host connections, or delete the unused connections from the table.

21. For each host adapter, repeat steps 16 through 20.

Verify Installation

To verify installation for your OpenVMS host, enter the following command:

```
SHOW DEVICES
```

Your host computer should report that it sees a device whose designation matches the identifier (CCL) that you assigned the controller(s). For example, if you assigned an identifier of **88**, your host computer will see device **\$1\$GGA88**. This verifies that your host computer is communicating with the controller.

Setting Up a Controller Pair

Power Up and Establish Communication

1. Connect the computer or terminal to the controller as shown in Figure 5-1. The connection to the computer is through the COM1 or COM2 ports.
2. Turn on the computer or terminal.
3. Apply power to the storage subsystem.
4. Configure the computer or terminal as follows:
 - 9600 baud
 - 8 data bits
 - 1 stop bit

- ❑ no parity
5. Press **Enter**. A copyright notice and the CLI prompt appear, indicating that you established a local connection with the controller.

Cabling a Controller Pair

The cabling for a controller pair is shown in Figure 5-3.

NOTE: It is a good idea to plug only the controller cables into the switch. The host cables are plugged into the switch as part of the configuration procedure (“Configuring a Controller Pair Using CLI,” page 5-10).

The following figure shows a controller pair with failover cabling showing one HBA per server with HSG80 controller in transparent failover mode.

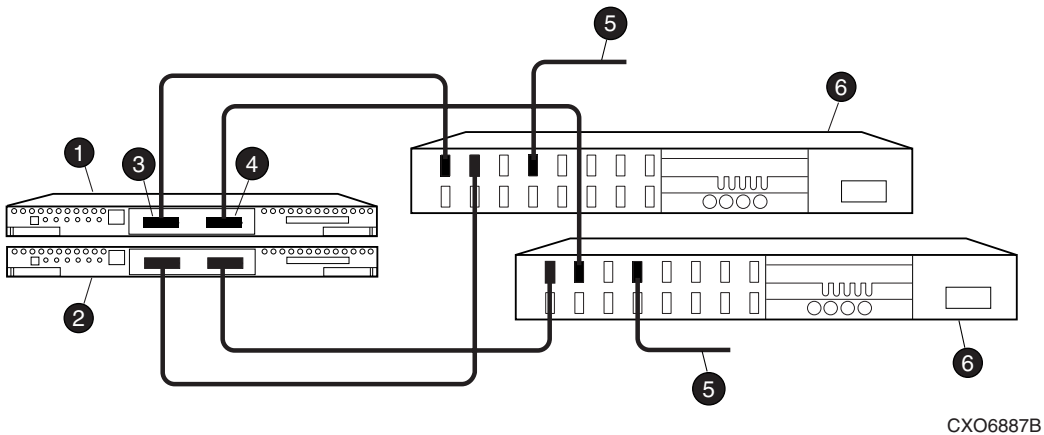

- | | |
|----------------|--|
| ❶ Controller A | ❷ Host port 2 |
| ❸ Controller B | ❸ Cable from the switch to the host FC adapter |
| ❹ Host port 1 | ❹ FC switch |

Figure 5-3. Controller pair failover cabling

Configuring a Controller Pair Using CLI

To configure a single controller using CLI involves the following processes:

- Configure Controller Settings.

- Restart the Controller.
- Set Time and Verify All Commands.
- Plug in the FC Cable and Verify Connections.
- Repeat Procedure for Each Host Adapter.
- Verify Installation.

1. Enter a SHOW THIS command to verify the node ID:

SHOW THIS

See “Worldwide Names (Node IDs and Port IDs),” page 1–18, for the location of the sticker.

The node ID is located in the third line of the SHOW THIS result:

HSG80> show this

Controller:

HSG80 ZG80900583 Software V8.6F-1, Hardware E11

NODE_ID = 5000-1FE1-0001-3F00

ALLOCATION_CLASS = 0

If the node ID is present, go to step 5.

If the node ID is all zeroes, enter the node ID and checksum, which are located on a sticker on the controller enclosure. Use the following syntax to enter the node ID:

SET THIS NODE_ID=*NNNN-NNNN-NNNN-NNNN nn*

Where: *NNNN-NNNN-NNNN-NNNN* is the node ID and *nn* is the checksum.

2. If the controller is not new from the factory, enter the following command to take it out of any failover mode that may have been previously configured:

SET NOFAILOVER

If the controller did have a failover mode previously set, the CLI may report an error. Clear the error with this command:

CLEAR_ERRORS CLI

3. Enter the following command to remove any previously configured connections:

SHOW CONNECTIONS

A list of named connections, if any, is displayed.

4. Delete these connections by entering the following command:

DELETE !NEWCON01

Repeat the Delete command for each of the listed connections. When completed, no connections will be displayed.

Configure Controller Settings

5. Set the SCSI version to SCSI-3 using the following command:

```
SET THIS SCSI_VERSION=SCSI-3
```

NOTE: Setting the SCSI version to SCSI-3 does not make the controller fully compliant with the SCSI-3 standards.

6. Assign an identifier for the communication LUN (also called the command console LUN, or CCL). The CCL must have a unique identifier that is a decimal number in the range 1 to 32767, and which is different from the identifiers of all units. Use the following syntax:

```
SET THIS IDENTIFIER=N
```

Identifier must be unique among all the controllers attached to the fabric within the specified allocation class.

7. Set the topology for the controller. If both ports are used, set topology for both ports:

```
SET THIS PORT_1_TOPOLOGY=FABRIC
```

```
SET THIS PORT_2_TOPOLOGY=FABRIC
```

If the controller is not factory-new, it may have another topology set, in which case these commands will result in an error message. If this happens, first take both ports offline, then reset the topology:

```
SET THIS PORT_1_TOPOLOGY=OFFLINE
```

```
SET THIS PORT_2_TOPOLOGY=OFFLINE
```

```
SET THIS PORT_1_TOPOLOGY=FABRIC
```

```
SET THIS PORT_2_TOPOLOGY=FABRIC
```

8. Set Allocation class to a decimal number between 0 and 999. The number must be unique across the fabric. Set allocation class using the following syntax:

```
SET THIS ALLOCATION_CLASS=N
```

Restart the Controller

9. Restart the controller, using the following command:

```
RESTART THIS
```

It takes about a minute for the CLI prompt to come back after a RESTART command.

Set Time and Verify All Commands

10. Set the time on the controller by entering the following syntax:

```
SET THIS TIME=DD-MMM-YYYY:HH:MM:SS
```

11. Use the FRUTIL utility to set up the battery discharge timer. Enter the following command to start FRUTIL:

```
RUN FRUTIL
```

When FRUTIL asks if you intend to replace the battery, answer “**Y**”:

```
Do you intend to replace this controller's cache battery? Y/N [N] Y
```

FRUTIL will print out a procedure, but will not give you a prompt. Ignore the procedure and press **Enter**.

12. Set up any additional optional controller settings, such as changing the CLI prompt. See the `SET THIS CONTROLLER/OTHER CONTROLLER` command in the *Compaq StorageWorks HSG80 Array Controller ACS Version 8.6 CLI Reference Guide* for the format of optional settings. Perform this step on both controllers.
13. Verify that all commands have taken effect by entering the following command:

```
SHOW THIS
```

14. Verify node ID, allocation class, SCSI version, failover mode, identifier, and port topology. The following display is a sample result of a SHOW THIS command, with the areas of interest in bold.

Controller:

HSG80 (C) DEC ZG09030200 Software V8.6F-1, Hardware E11

NODE_ID = 5000-1FE1-0000-0000

ALLOCATION_CLASS = 1

SCSI_VERSION = SCSI-3

Configured for dual-redundancy with 2GOP030245

Device Port SCSI address 7

Time: 10-Mar-2001:12:30:34

Command Console LUN is lun 0 (IDENTIFIER = 88)

Host PORT_1:

Reported PORT_ID = 5000-1FE1-0000-0001

PORT_1_TOPOLOGY = FABRIC (standby)

Address = 210313

Host PORT_2:

Reported PORT_ID = 5000-1FE1-0000-0002

PORT_2_TOPOLOGY = FABRIC (fabric up)

Address = 210513

NOREMOTE_COPY

.....

.

15. Turn on the switches if not done previously.

If you want to communicate with the FC switches through Telnet, set an IP address for each switch. See the manuals that came with the switches for details.

Plug in the FC Cable and Verify Connections

16. Plug the FC cable from the first host adapter into the switch. Enter a SHOW CONNECTIONS command to view the connection table:

SHOW CONNECTIONS

The first connection will have one or more entries in the connection table. Each connection will have a default name of the form !NEWCONxx, where xx is a number representing the order in which the connection was added to the connection table.

For a description of why plugging in one adapter can result in multiple connections, see “Numbers of Connections,” page 1-10.

17. Rename the connections to something meaningful to the system and easy to remember. For example, to assign the name ANGEL1A1 to connection !NEWCON01, enter:

```
RENAME !NEWCON01 ANGEL1A1
```

Compaq recommends using a naming convention, see “Naming Connections,” page 1-9.

18. Specify the operating system for the connection:

```
SET ANGEL1A1 OPERATING_SYSTEM=VMS
```

19. Verify the changes:

```
SHOW CONNECTIONS
```

Mark or tag all Fibre Channel cables at both ends for ease of maintenance.

Repeat Procedure for Each Host Adapter Connection

20. Repeat steps 17, 18, and 19 for each of that adapter’s host connections or delete the unwanted connections from the table.
21. For each host adapter, repeat steps 16 through 20.

Verify Installation

To verify installation for your OpenVMS host, enter the following command:

```
SHOW DEVICES
```

Your host computer should report that it sees a device whose designation matches the identifier (CCL) that you assigned the controller(s). For example, if you assigned an identifier of **88**, your host computer will see device **\$1\$GGA88**. This verifies that your host computer is communicating with the controller pair.

Configuring Devices

The disks on the device bus of the HSG80 can be configured manually or with the CONFIG utility. The CONFIG utility is easier. Invoke CONFIG with the following command:

```
RUN CONFIG
```

CONFIG takes about two minutes to discover and to map the configuration of a completely populated storage system.

Configuring a Stripese

1. Create the stripeset by adding its name to the controller's list of storagesets and by specifying the disk drives it contains. Use the following syntax:

```
ADD STRIPESET STRIPESET-NAME DISKNNNNN DISKNNNNN.....
```

2. Initialize the stripeset, specifying any desired switches:

```
INITIALIZE STRIPESET-NAME SWITCHES
```

See “Initialization Switches” on page 2–25 for a description of the initialization switches.

3. Verify the stripeset configuration:

```
SHOW STRIPESET-NAME
```

4. Assign the stripeset a unit number to make it accessible by the hosts. See “Assigning Unit Numbers and Unit Qualifiers” on page 5–20.

For example:

The commands to create Stripe1, a stripeset consisting of three disks (DISK10000, DISK20000, and DISK10100) and having a chunksize of 128:

```
ADD STRIPESET STRIPE1 DISK10000 DISK20000 DISK10100
```

```
INITIALIZE STRIPE1 CHUNKSIZE=128
```

```
SHOW STRIPE1
```

Configuring a Mirrorset

1. Create the mirrorset by adding its name to the controller's list of storagesets and by specifying the disk drives it contains. Optionally, you can append mirrorset switch values:

```
ADD MIRRORSET MIRRORSET-NAME DISKNNNNN DISKNNNNN SWITCHES
```

NOTE: See the ADD MIRRORSET command in the *Compaq StorageWorks HSG80 Array Controller ACS Version 8.6 CLI Reference Guide* for a description of the mirrorset switches.

2. Initialize the mirrorset, specifying any desired switches:

```
INITIALIZE MIRRORSET-NAME SWITCHES
```

See “Initialization Switches” on page 2–25 for a description of the initialization switches.

3. Verify the mirrorset configuration:

```
SHOW MIRRORSET-NAME
```

4. Assign the mirrorset a unit number to make it accessible by the hosts. See “Assigning Unit Numbers and Unit Qualifiers” on page 5–20.

For example:

The commands to create Mirr1, a mirrorset with two members (DISK10000 and DISK20000), and to initialize it using default switch settings:

```
ADD MIRRORSET MIRR1 DISK10000 DISK20000
INITIALIZE MIRR1
SHOW MIRR1
```

Configuring a RAIDset

1. Create the RAIDset by adding its name to the controller's list of storagesets and by specifying the disk drives it contains. Optionally, you can specify RAIDset switch values:

```
ADD RAIDSET RAIDSET-NAME DISKNNNNN DISKNNNNN DISKNNNNN SWITCHES
```

NOTE: See the ADD RAIDSET command in the *Compaq StorageWorks HSG80 Array Controller ACS Version 8.6 CLI Reference Guide* for a description of the RAIDset switches.

2. Initialize the RAIDset, specifying any desired switches:

```
INITIALIZE RAIDSET-NAME SWITCH
```

NOTE: Compaq recommends that you allow initial reconstruct to complete before allowing I/O to the RAIDset. Not doing so may generate forced errors at the host level. To determine whether initial reconstruct has completed, enter SHOW RAIDSET FULL.

See “Initialization Switches” on page 2–25 for a description of the initialization switches.

3. Verify the RAIDset configuration:

```
SHOW RAIDSET-NAME
```

4. Assign the RAIDset a unit number to make it accessible by the hosts. See “Assigning Unit Numbers and Unit Qualifiers” on page 5-20.

For example:

The commands to create RAID1, a RAIDset with three members (DISK10000, DISK20000, and DISK10100) and to initialize it with default values:

```
ADD RAIDSET RAID1 DISK10000 DISK20000 DISK10100
INITIALIZE RAID1
SHOW RAID1
```

Configuring a Striped Mirrorset

1. Create, but do not initialize, at least two mirrorsets.

See “Configuring a Mirrorset” on page 5-16.

2. Create a stripeset and specify the mirrorsets it contains:

```
ADD STRIPESET STRIPESET-NAME MIRRORSET-1 MIRRORSET-2...MIRRORSET-N
```

3. Initialize the striped mirrorset, specifying any desired switches:

```
INITIALIZE STRIPESET-NAME SWITCH
```

See “Initialization Switches” on page 2-25 for a description of the initialization switches.

4. Verify the striped mirrorset configuration:

```
SHOW STRIPESET-NAME
```

5. Assign the stripeset mirrorset a unit number to make it accessible by the hosts. See “Assigning Unit Numbers and Unit Qualifiers” on page 5-20.

For example:

The commands to create Stripe1, a striped mirrorset that comprises Mirr1, Mirr2, and Mirr3, each of which is a two-member mirrorset:

```
ADD MIRRORSET MIRR1 DISK10000 DISK20000
ADD MIRRORSET MIRR2 DISK20100 DISK10100
ADD MIRRORSET MIRR3 DISK10200 DISK20200
ADD STRIPESET STRIPE1 MIRR1 MIRR2 MIRR3
INITIALIZE STRIPE1
SHOW STRIPE1
```

Configuring a Single-Disk Unit (JBOD)

1. Initialize the disk drive, specifying any desired switches:

```
INITIALIZE DISK-NAME SWITCHES
```

See “Initialization Switches” on page 2–25 for a description of the initialization switches.

2. Verify the configuration by entering the following command:

```
SHOW DISK-NAME
```

3. Assign the disk a unit number to make it accessible by the hosts. See “Assigning Unit Numbers and Unit Qualifiers” on page 5–20.

Configuring a Partition

1. Initialize the storageset or disk drive, specifying any desired switches:

```
INITIALIZE STORAGESET-NAME SWITCHES
```

or

```
INITIALIZE DISK-NAME SWITCHES
```

See “Initialization Switches” on page 2–25 for a description of the initialization switches.

2. Create each partition in the storageset or disk drive by indicating the partition's size. Also specify any desired switch settings:

```
CREATE_PARTITION STORAGESET-NAME SIZE=N SWITCHES
```

or

```
CREATE_PARTITION DISK-NAME SIZE=N SWITCHES
```

where N is the percentage of the disk drive or storageset that will be assigned to the partition. Enter SIZE=LARGEST to let the controller assign the largest free space available to the partition.

NOTE: See the CREATE_PARTITION command in the *Compaq StorageWorks HSG80 Array Controller ACS Version 8.6 CLI Reference Guide* for a description of the partition switches.

3. Verify the partitions:

```
SHOW STORAGESET-NAME
```

or

```
SHOW DISK-NAME
```

The partition number appears in the first column, followed by the size and starting block of each partition.

4. Assign the partition a unit number to make it accessible by the hosts. See “Assigning Unit Numbers and Unit Qualifiers” on page 5-20.

For example:

The commands to create RAID1, a three-member RAIDset, then partition it into two storage units are shown below.

```
ADD RAIDSET RAID1 DISK10000 DISK20000 DISK10100
INITIALIZE RAID1
CREATE_PARTITION RAID1 SIZE=25
CREATE_PARTITION RAID1 SIZE=LARGEST
SHOW RAID1
```

Assigning Unit Numbers and Unit Qualifiers

Each storageset, partition, or single (JBOD) disk must be assigned a unit number for the host to access. As the units are added, their properties can be specified through the use of command qualifiers, which are discussed in detail under the ADD UNIT command in the *Compaq StorageWorks HSG80 Array Controller ACS Version 8.6 CLI Reference Guide*.

Because of different SCSI versions, refer to the section “Assigning Unit Numbers Depending on SCSI_VERSION,” page 1-13. The choice for SCSI_VERSION effects how certain unit numbers and host connection offsets interact.

Each unit can be reserved for the exclusive use of a host or group of hosts. See ..

Assigning a Unit Number to a Storageset

To assign a unit number to a storageset, use the following syntax:

```
ADD UNIT UNIT-NUMBER STORAGESET-NAME
```

For example:

To assign unit D102 to RAIDset R1, use the following command:

```
ADD UNIT D102 R1
```

Assigning a Unit Number to a Single (JBOD) Disk

To assign a unit number to a single (JBOD) disk, use the following syntax:

```
ADD UNIT UNIT-NUMBER DISK-NAME
```

For example:

To assign unit D4 to DISK20300, use the following command:

```
ADD UNIT D4 DISK20300
```

Assigning a Unit Number to a Partition

To assign a unit number to a partition, use the following syntax:

```
ADD UNIT UNIT-NUMBER STORAGESET-NAME PARTITION=PARTITION-NUMBER
```

For example:

To assign unit D100 to partition 3 of mirrorset mirr1, use the following command:

```
ADD UNIT D100 MIRR1 PARTITION=3
```

Assigning Unit Identifiers

One unique step is required when configuring storage units for OpenVMSSGI IRIX: specifying an identifier (or LUN ID alias) for each unit. A unique identifier is required for each unit (virtual disk). This identifier must be unique in the cluster.

This section gives two examples of setting an identifier for a previously created unit: one using CLI and one using SWCC. The CLI uses the older terms “identifier” and “unit”, while SWCC uses the terms “LUN ID alias” and “virtual disk”.

Identifier = LUN ID alias

Unit = virtual disk

Using CLI to Specify Identifier for a Unit

The command syntax for setting the identifier for a previously created unit (virtual disk) follows:

```
SET UNIT_NUMBER IDENTIFIER=NN
```

NOTE: It is strongly suggested that, for simplicity, the identifier match the unit number. For example, to set an identifier of 97 for unit D97, use the following command:

```
SET D97 IDENTIFIER=97
```

Using SWCC to Specify LUN ID Alias for a Virtual Disk

Setting a LUN ID alias for a virtual disk is the same as setting a unit identifier. To set the LUN ID alias for a previously created virtual disk, perform the following procedure:

1. Open the storage window, where you see the properties for that virtual disk.
2. Click on the Settings Tab to see changeable properties.
3. Click on the **Enable LUN ID Alias** button.
4. Enter the LUN ID alias (identifier) in the appropriate field. It is strongly suggested that, for simplicity, the LUN ID alias match the virtual disk number.

NOTE: If, while using the Compaq HBA, you create a unit after your server is online, you must run the SaveCfg command to see the unit.

Preferring Units

In multiple-bus failover mode, individual units can be preferred to a specific controller. For example, to prefer unit D102 to “this controller,” use the following command:

```
SET D102 PREFERRED_PATH=THIS
```

RESTART commands must be issued to both controllers for this command to take effect:

```
RESTART OTHER_CONTROLLER
```

```
RESTART THIS_CONTROLLER
```

NOTE: The controllers need to restart together for the preferred settings to take effect. The RESTART *this_controller* command must be entered immediately after the RESTART *other_controller* command.

Configuration Options

Changing the CLI Prompt

To change the CLI prompt, enter a 1- to 16- character string as the new prompt, according to the following syntax:

```
SET THIS_CONTROLLER PROMPT = "NEW PROMPT"
```

If you are configuring dual-redundant controllers, also change the CLI prompt on the "other controller." Use the following syntax:

```
SET OTHER_CONTROLLER PROMPT = "NEW PROMPT"
```

NOTE: It is suggested that the prompt name reflect some information about the controllers. For example, if the subsystem is the third one in a lab, name the top controller prompt, LAB3A and the bottom controller, LAB3B.

Mirroring cache

To specify mirrored cache, use the following syntax:

```
SET THIS_MIRRORED_CACHE
```

Adding Disk Drives

If you add new disk drives to the subsystem, the disk drives must be added to the controllers' list of known devices:

- To add one new disk drive to the list of known devices, use the following syntax:

```
ADD DISK DISKNNNNN P T L
```

- To add several new disk drives to the list of known devices, enter the following command:

```
RUN CONFIG
```

Adding a Disk Drive to the Spareset

The spareset is a collection of spare disk drives that are available to the controller should it need to replace a failed member of a RAIDset or mirrorset.

NOTE: This procedure assumes that the disks that you are adding to the spareset have already been added to the controller's list of known devices.

To add the disk drive to the controller's spareset list, use the following syntax:

```
ADD SPARESET DISKNNNNN
```

Repeat this step for each disk drive you want to add to the spareset:

For example:

The following example shows the syntax for adding DISK11300 and DISK21300 to the spareset.

```
ADD SPARESET DISK11300
```

```
ADD SPARESET DISK21300
```

Removing a Disk Drive from the Spareset

You can delete disks in the spareset if you need to use them elsewhere in your subsystem.

1. Show the contents of the spareset entering the following command:

```
SHOW SPARESET
```

2. Delete the desired disk drive entering the following command:

```
DELETE SPARESET DISKNNNNN
```

NOTE: The RUN CONFIG command does not delete disks from the controllers' device table if a disk has been physically removed or replaced. In this case, you must use the command:

```
DELETE DISKNNNN.
```

3. Verify the contents of the spareset by entering the following command:

```
SHOW SPARESET
```

Enabling Autospare

With AUTOSPARE enabled on the failedset, any new disk drive that is inserted into the PTL location of a failed disk drive is automatically initialized and placed into the spareset. If initialization fails, the disk drive remains in the failedset until you manually delete it from the failedset.

To enable autospare, use the following command:

```
SET FAILEDSET AUTOSPARE
```

To disable autospare, use the following command:

```
SET FAILEDSET NOAUTOSPARE
```

During initialization, AUTOSPARE checks to see if the new disk drive contains metadata. Metadata is information the controller writes on the disk drive when the disk drive is configured into a storageset. Therefore, the presence of metadata indicates that the disk drive belongs to, or has been used by, a storageset. If the disk drive contains metadata, initialization stops. (A new disk drive will not contain metadata but a repaired or reused disk drive might. To erase metadata from a disk drive, add it to the controller's list of devices, then set it to be nottransportable and initialize it.)

Deleting a Storageset

NOTE: If the storageset you are deleting is partitioned, you must delete each partitioned unit before you can delete the storageset.

1. Show the storageset's configuration:

```
SHOW STORAGESET-NAME
```

2. Delete the unit number that uses the storageset. Use the following command:

```
DELETE UNIT-NUMBER
```

3. Delete the storageset. Use the following command:

```
DELETE STORAGESET-NAME
```

4. Verify the configuration:

```
SHOW STORAGESET-NAME
```

Changing Switches for a Storageset or Device

You can optimize a storageset or device at any time by changing the switches that are associated with it. Remember to update the storageset profile when changing its switches.

Displaying the Current Switches

To display the current switches for a storageset or single-disk unit, enter a SHOW command, specifying the FULL switch:

```
SHOW STORAGESET-NAME
```

or

```
SHOW DEVICE-NAME FULL
```

Changing RAIDset and Mirrorset Switches

Use the SET *storageset-name* command to change the RAIDset and Mirrorset switches associated with an existing storageset.

For example, the following command changes the replacement policy for RAIDset RAID1 to BEST_FIT:

```
SET RAID1 POLICY=BEST_FIT
```

Changing Device Switches

Use the SET *device-name* command to change the device switches.

For example, to request a data transfer rate of 20 MHz for DISK10000:

```
SET DISK10000 TRANSFER_RATE_REQUESTED=20MHZ
```

Changing Initialize Switches

The initialization switches cannot be changed without destroying the data on the storageset or device. These switches are integral to the formatting and can only be changed by reinitializing the storageset. Initializing a storageset is similar to formatting a disk drive; all data is destroyed during this procedure.

Changing Unit Switches

Use the SET *unit-name* command to change the characteristics of a unit.

For example, the following command enables write protection for unit D100:

```
SET D100 WRITE_PROTECT
```

Verifying Storage Configuration from the Host

This chapter briefly describes how to verify that multiple paths exist to virtual disk units.

After configuring units (virtual disks) through either the CLI or SWCC reboot the host to enable access to the new storage and enter the following command to rescan the bus:

```
$ MC SYSMAN 10 AUTO
```

. After the host restarts, verify that the disk is correctly presented to the host. The command to use consists of the following syntax:

```
$ SHOW DEVICE/FULL <NAME OF VIRTUAL DISK>
```

For example, disk \$1\$DGA1 was configured with two paths, one path through host bus adapter PGA0 and one through host bus adapter PGB0.

Use the following command to verify the configuration:

```
$ SHOW DEVICE/FULL $1$DGA1
```

The disk information returned is shown in the following table:

```
Disk $1$DGA1: (NOCORD), device type DEC HSG80, is online, file-oriented
device, shareable, device has multiple I/O paths, served to cluster via
MSCP Server, error logging is enabled.
Error count 0      Operations completed 0
Owner process ""   Owner UIC      [SYSTEM]
Owner process ID  00000000   Dev Prot S:RWPL,O:RWPL,G:R,W
Reference count 0   Default buffer size 512
Allocation class   1
I/O paths to device 2
Path PGA0.5000-1FE1-0000-0173 (NOCORD), primary path, current path.
Error count 0      Operations completed 0
```

6-2 *HSG80 ACS Solution Software Version 8.6 for Compaq OpenVMS Installation and Configuration Guide*

```
Path PGB0.5000-1FE1-0000-0171 (NOCORD).  
Error count 0    Operations completed 0
```

Chapter 7

Configuration Example Using CLI

This chapter presents an example of how to configure a storage subsystem using the Command Line Interpreter (CLI). The CLI configuration example shown assumes:

- A normal, new controller pair, meaning:
 - NODE ID set
 - No previous failover mode
 - No previous topology set
- Full array with no expansion cabinet
- PCMCIA cards installed in both controllers

A storage subsystem example is shown in Figure 7–1. The example system contains three non-clustered VMS hosts, as shown in Figure 7–2. From the hosts' point of view, each host will have four paths to its own virtual disks. The resulting virtual system, from the host's point of view, is shown in Figure 7–3.

Figure 7-1 shows an example storage system map for the BA370 enclosure. Details on building your own map are described in Chapter 2. Templates to help you build your storage map are supplied in Appendix A.

	Port						
	1	2	3	4	5	6	
Power Supply	D2 S2 DISK10300	D2 S2 DISK20300	D2 S2 DISK30300	D2 S2 DISK40300	D2 D101 DISK50300	spareset member DISK60300	Power Supply 3
Power Supply	D0 S1 MI DISK10200	D0 S1 M1 DISK20200	D0 S1 M2 DISK30200	D0 S1 M2 DISK40200	D1 M3 DISK50200	D1 M3 DISK60200	Power Supply 2
Power Supply	D120 R2 DISK10100	D120 R2 DISK20100	D120 R2 DISK30100	D120 R2 DISK40100	D120 R2 DISK50100	D120 R2 DISK60100	Power Supply 1
Power Supply	D102 R1 DISK10000	D102 R1 DISK20000	D102 R1 DISK30000	D102 R1 DISK40000	D102 R1 DISK50000	D102 R1 DISK60000	Power Supply 0

Figure 7-1. Example storage map for the BA370 Enclosure

The figure shows a representative multiple-bus failover configuration. Restricting the access of unit D101 to host BLUE can be done by enabling only the connections to host BLUE. At least two connections must be enabled for multiple-bus failover to work. For most operating systems, it is desirable to have all connections to the host enabled. The example system, shown in Figure 7-2, contains three non-clustered VMS hosts.

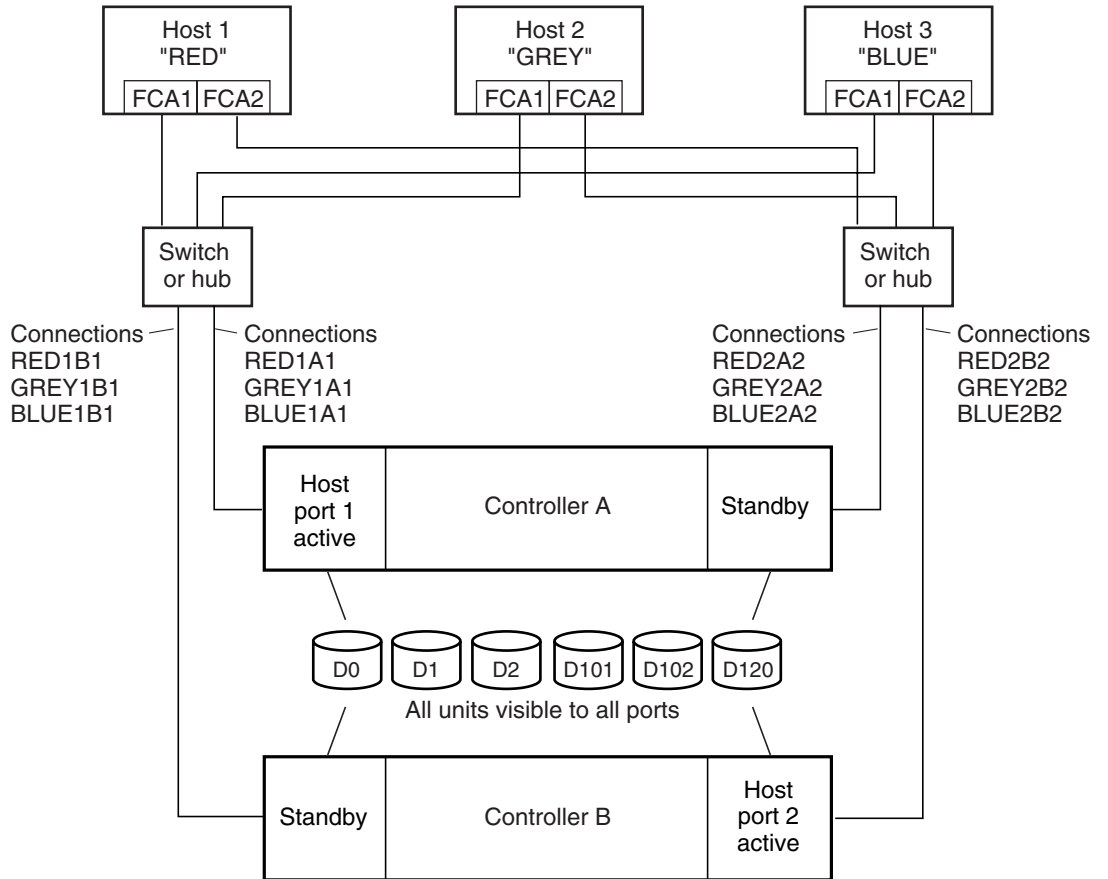

NOTE: FCA = Fibre Channel Adapter

CXO7547A

Figure 7-2. Example system

The following figure represents units that are logical or virtual disks comprised of storagesets configured from physical disks.

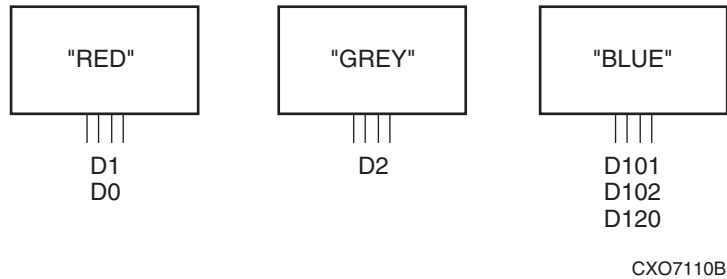

Figure 7-3. Example virtual system layout from the hosts' point of view

CLI Configuration Example

The series of commands and information presented in this section provides a CLI configuration example. Text conventions used in this section are listed below:

- Text in *italics* indicates an action you take.
- Text in THIS FORMAT, indicates a command you type. Be certain to press **Enter** after each command.
- Text enclosed within a box, indicates information that is displayed by the CLI interpreter.
- **NOTE** text provides additional helpful information.

NOTE: "This" controller is top controller (A).

Plug serial cable from maintenance terminal into top controller.

```
CLEAR CLI
SET MULTIBUS COPY=THIS
CLEAR CLI
SET THIS SCSI_VERSION=SCSI-3
SET THIS IDENTIFIER=88
SET THIS PORT_1_TOPOLOGY=FABRIC
SET THIS PORT_2_TOPOLOGY=FABRIC
SET OTHER PORT_1_TOPOLOGY=FABRIC
SET OTHER PORT_2_TOPOLOGY=FABRIC
SET THIS ALLOCATION_CLASS=1
```

```
RESTART OTHER
RESTART THIS
SET THIS TIME=10-Mar-2001:12:30:34
RUN FRUTIL
```

```
Do you intend to replace this controller's cache battery? Y/N [Y]
```

Y

Plug serial cable from maintenance terminal into bottom controller.

NOTE: Bottom controller (B) becomes “this” controller.

```
RUN FRUTIL
```

```
Do you intend to replace this controller's cache battery? Y/N [Y]
```

Y

```
SET THIS MIRRORED_CACHE
```

NOTE: This command causes the controllers to restart.

```
SET THIS PROMPT="BTVS BOTTOM"
```

```
SET OTHER PROMPT="BTVS TOP"
```

```
SHOW THIS
```

```
SHOW OTHER
```

Plug in the Fibre Channel cable from the first adapter in host “RED.”

```
SHOW CONNECTIONS
```

```
RENAME !NEWCON00 RED1B1
```

```
SET RED1B1 OPERATING_SYSTEM=VMS
```

```
RENAME !NEWCON01 RED1A1
```

```
SET RED1A1 OPERATING_SYSTEM=VMS
```

```
SHOW CONNECTIONS
```

NOTE: Connection table sorts alphabetically.

Connection Name	Operating System	Controller	Port	Address	Status	Unit Offset
RED1A1	VMS	OTHER	1	XXXXXX	OL other	0
HOST_ID=XXXX-XXXX-XXXX-XXXX			ADAPTER_ID=XXXX-XXXX-XXXX-XXXX			
RED1B1	VMS	THIS	1	XXXXXX	OL this	0
HOST_ID=XXXX-XXXX-XXXX-XXXX			ADAPTER_ID=XXXX-XXXX-XXXX-XXXX			

Mark or tag both ends of Fibre Channel cables.

Plug in the Fibre Channel cable from the second adapter in host "RED."

SHOW CONNECTIONS

Connection Name	Operating System	Controller	Port	Address	Status	Unit Offset
!NEWCON02	VMS	THIS	2	XXXXXX	OL this	0
HOST_ID=XXXX-XXXX-XXXX-XXXX			ADAPTER_ID=XXXX-XXXX-XXXX-XXXX			
!NEWCON03	VMS	OTHER	2	XXXXXX	OL other	0
HOST_ID=XXXX-XXXX-XXXX-XXXX			ADAPTER_ID=XXXX-XXXX-XXXX-XXXX			
RED1A1	VMS	OTHER	1	XXXXXX	OL other	0
...						

```

RENAME !NEWCON02 RED2B2
SET RED2B2 OPERATING_SYSTEM=VMS
RENAME !NEWCON02 RED2A2
SET RED2A2 OPERATING_SYSTEM=VMS
SHOW CONNECTIONS
    
```

Connection Name	Operating System	Controller	Port	Address	Status	Unit Offset
RED1A1	VMS	OTHER	1	XXXXXX	OL other	0
				HOST_ID=XXXX-XXXX-XXXX-XXXX	ADAPTER_ID=XXXX-XXXX-XXXX-XXXX	
RED1B1	VMS	THIS	1	XXXXXX	OL this	0
				HOST_ID=XXXX-XXXX-XXXX-XXXX	ADAPTER_ID=XXXX-XXXX-XXXX-XXXX	
RED2A2	VMS	OTHER	2	XXXXXX	OL other	0
				HOST_ID=XXXX-XXXX-XXXX-XXXX	ADAPTER_ID=XXXX-XXXX-XXXX-XXXX	
RED2B2	VMS	THIS	2	XXXXXX	OL this	0
				HOST_ID=XXXX-XXXX-XXXX-XXXX	ADAPTER_ID=XXXX-XXXX-XXXX-XXXX	

Mark or tag both ends of Fibre Channel cables

Repeat this process to add connections from the other two hosts. The resulting connection table should appear similar to the following:

Connection Name	Operating System	Controller	Port	Address	Status	Unit Offset
GREY1A1	VMS	OTHER	1	XXXXXX	OL other	0
				HOST_ID=XXXX-XXXX-XXXX-XXXX	ADAPTER_ID=XXXX-XXXX-XXXX-XXXX	
GREY1B1	VMS	THIS	1	XXXXXX	OL this	0
				HOST_ID=XXXX-XXXX-XXXX-XXXX	ADAPTER_ID=XXXX-XXXX-XXXX-XXXX	
GREY2A2	VMS	OTHER	2	XXXXXX	OL other	0
				HOST_ID=XXXX-XXXX-XXXX-XXXX	ADAPTER_ID=XXXX-XXXX-XXXX-XXXX	
GREY2B2	VMS	THIS	2	XXXXXX	OL this	0
				HOST_ID=XXXX-XXXX-XXXX-XXXX	ADAPTER_ID=XXXX-XXXX-XXXX-XXXX	
BLUE1A1	VMS	OTHER	1	XXXXXX	OL other	0
				HOST_ID=XXXX-XXXX-XXXX-XXXX	ADAPTER_ID=XXXX-XXXX-XXXX-XXXX	
BLUE1B1	VMS	THIS	1	XXXXXX	OL this	0
				HOST_ID=XXXX-XXXX-XXXX-XXXX	ADAPTER_ID=XXXX-XXXX-XXXX-XXXX	
BLUE2A2	VMS	OTHER	2	XXXXXX	OL other	0
				HOST_ID=XXXX-XXXX-XXXX-XXXX	ADAPTER_ID=XXXX-XXXX-XXXX-XXXX	

BLUE2B2	VMS	THIS	2	XXXXXX	OL this	0
HOST_ID=XXXX-XXXX-XXXX-XXXX			ADAPTER_ID=XXXX-XXXX-XXXX-XXXX			
RED1A1	VMS	OTHER	1	XXXXXX	OL other	0
HOST_ID=XXXX-XXXX-XXXX-XXXX			ADAPTER_ID=XXXX-XXXX-XXXX-XXXX			
RED1B1	VMS	THIS	1	XXXXXX	OL this	0
HOST_ID=XXXX-XXXX-XXXX-XXXX			ADAPTER_ID=XXXX-XXXX-XXXX-XXXX			
RED2A2	VMS	OTHER	2	XXXXXX	OL other	0
HOST_ID=XXXX-XXXX-XXXX-XXXX			ADAPTER_ID=XXXX-XXXX-XXXX-XXXX			
RED2B2	VMS	THIS	2	XXXXXX	OL this	0
HOST_ID=XXXX-XXXX-XXXX-XXXX			ADAPTER_ID=XXXX-XXXX-XXXX-XXXX			

```

SET CONNECTION BLUE1A1 UNIT_OFFSET=100
SET CONNECTION BLUE1B1 UNIT_OFFSET=100
SET CONNECTION BLUE2A2 UNIT_OFFSET=100
SET CONNECTION BLUE2B2 UNIT_OFFSET=100

RUN CONFIG

ADD RAIDSET R1 DISK10000 DISK20000 DISK30000 DISK40000 DISK50000 DISK60000
INITIALIZE R1

ADD UNIT D102 R1 DISABLE_ACCESS_PATH=ALL
SET D102 ENABLE_ACCESS_PATH=(RED1A1, RED1B1, RED2A2, RED2B2)
SET D102 IDENTIFIER=102

ADD RAIDSET R2 DISK10100 DISK20100 DISK30100 DISK40100 DISK50100 DISK60100
INITIALIZE R2

ADD UNIT D120 R2 DISABLE_ACCESS_PATH=ALL
SET D120 ENABLE_ACCESS_PATH=(BLUE1A1, BLUE1B1, BLUE2A2, BLUE2B2)
SET D120 IDENTIFIER=120

ADD MIRRORSET MI DISK10200 DISK20200
ADD MIRRORSET M2 DISK30200 DISK40200
ADD STRIPESET S1 M1 M2
INITIALIZE S1

ADD UNIT D0 S1 DISABLE_ACCESS_PATH=ALL
SET D0 ENABLE_ACCESS_PATH=(GREY1A1, GREY1B1, GREY2A2, GREY2B2)

```



```
SET D0 IDENTIFIER=0
ADD MIRRORSET M3 DISK50200 DISK60200
INITIALIZE M3
ADD UNIT D1 M3 DISABLE_ACCESS_PATH=ALL
SET D1 ENABLE_ACCESS_PATH=(BLUE1A1, BLUE1B1, BLUE2A2, BLUE2B2)
SET D1 IDENTIFIER=1
ADD STRIPESSET S2 DISK10300 DISK20300 DISK30300 DISK40300
INITIALIZE S2
ADD UNIT D2 S2 DISABLE_ACCESS_PATH=ALL
SET D2 ENABLE_ACCESS_PATH=(GREY1A1, GREY1B1, GREY2A2, GREY2B2)
SET D2 IDENTIFIER=2
INITIALIZE DISK50300
ADD UNIT D101 DISK50300 DISABLE_ACCESS_PATH=ALL
SET D101 ENABLE_ACCESS_PATH=(BLUE1A1, BLUE1B1, BLUE2A2, BLUE2B2)
SET D101 IDENTIFIER=101
ADD SPARESET DISK60300
SHOW UNITS ALL
```

Backing Up the Subsystem, Cloning Data for Backup, and Moving Stagesets

This chapter describes some common procedures that are not mentioned previously in this guide. The following information is included in this chapter:

- “Backing Up the Subsystem Configuration,” page 8–1
- “Cloning Data for Backup,” page 8–2
- “Moving Stagesets,” page 8–6

Backing Up the Subsystem Configuration

The controller stores information about the subsystem configuration in its nonvolatile memory. This information could be lost if the controller fails or when you replace a module in the subsystem.

Use the following command to produce a display that shows if the save configuration feature is active and which devices are being used to store the configuration.

```
SHOW THIS_CONTROLLER FULL
```

The resulting display includes a line that indicates status and how many devices have copies of the configuration. The last line shows on how many devices the configuration is backed up.

The `SHOW DEVICES FULL` command shows which disk drive are set up to back up the configuration. The syntax for this command is shown below:

```
SHOW DEVICES FULL
```

Cloning Data for Backup

Use the CLONE utility to duplicate the data on any unpartitioned single-disk unit, stripeset, mirrorset, or striped mirrorset in preparation for backup. When the cloning operation is complete, you can back up the clones rather than the storageset or single-disk unit, which can continue to service its I/O load. When you are cloning a mirrorset, CLONE does not need to create a temporary mirrorset. Instead, it adds a temporary member to the mirrorset and copies the data onto this new member.

The CLONE utility creates a temporary, two-member mirrorset for each member in a single-disk unit or stripeset. Each temporary mirrorset contains one disk drive from the unit you are cloning and one disk drive onto which CLONE copies the data. During the copy operation, the unit remains online and active so that the clones contain the most up-to-date data.

After the CLONE utility copies the data from the members to the clones, it restores the unit to its original configuration and creates a clone unit you can back up. The CLONE utility uses steps shown in Figure 8-1 to duplicate each member of a unit.

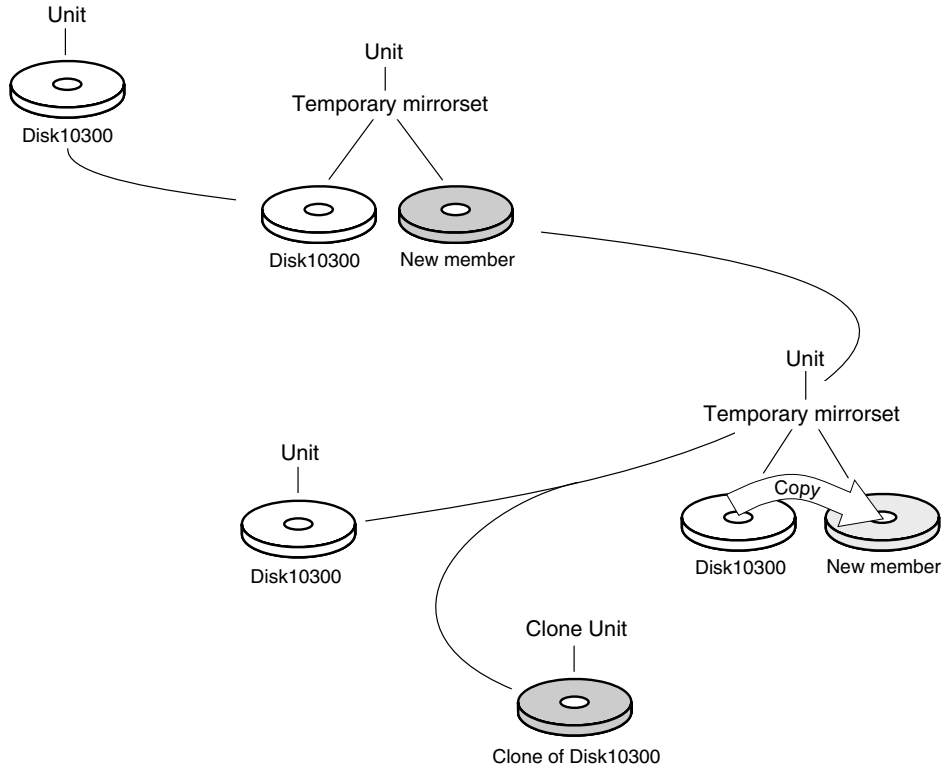

CXO5510A

Figure 8-1. Steps the CLONE utility follows for duplicating unit members

Use the following steps to clone a single-disk unit, stripeset, or mirrorset:

1. Establish a connection to the controller that accesses the unit you want to clone.
2. Start CLONE using the following command:

```
RUN CLONE
```
3. When prompted, enter the unit number of the unit you want to clone.
4. When prompted, enter a unit number for the clone unit that CLONE will create.
5. When prompted, indicate how you would like the clone unit to be brought online: either automatically or only after your approval.
6. When prompted, enter the disk drives you want to use for the clone units.
7. Back up the clone unit.

The following example shows the commands you would use to clone storage unit D98. The clone command terminates after it creates storage unit D99, a clone or copy of D98.

```
RUN CLONE
CLONE LOCAL PROGRAM INVOKED
UNITS AVAILABLE FOR CLONING:
    98
ENTER UNIT TO CLONE? 98
CLONE WILL CREATE A NEW UNIT WHICH IS A COPY OF UNIT 98.
ENTER THE UNIT NUMBER WHICH YOU WANT ASSIGNED TO THE NEW UNIT? 99
THE NEW UNIT MAY BE ADDED USING ONE OF THE FOLLOWING METHODS:
1. CLONE WILL PAUSE AFTER ALL MEMBERS HAVE BEEN COPIED. THE USER MUST THEN
   PRESS RETURN TO CAUSE THE NEW UNIT TO BE ADDED.
2. AFTER ALL MEMBERS HAVE BEEN COPIED, THE UNIT WILL BE ADDED AUTOMATICALLY.
UNDER WHICH ABOVE METHOD SHOULD THE NEW UNIT BE ADDED[ ]? 1
DEVICES AVAILABLE FOR CLONE TARGETS:
DISK20200 (SIZE=832317)
DISK20300 (SIZE=832317)
USE AVAILABLE DEVICE DISK20200(SIZE=832317) FOR MEMBER DISK10300(SIZE=832317)
(Y,N) [Y]? Y
MIRROR DISK10300 C_MA
SET C_MA NOPOLICY
SET C_MA MEMBERS=2
SET C_MA REPLACE=DISK20200
DEVICES AVAILABLE FOR CLONE TARGETS:
DISK20300 (SIZE=832317)
```

USE AVAILABLE DEVICE DISK20300(SIZE=832317) FOR MEMBER DISK10000(SIZE=832317)
(Y,N) [Y]? Y

MIRROR DISK10000 C_MB

SET C_MB NOPOLICY

SET C_MB MEMBERS=2

SET C_MB REPLACE=DISK20300

COPY IN PROGRESS FOR EACH NEW MEMBER. PLEASE BE PATIENT...

.
.

COPY FROM DISK10300 TO DISK20200 IS 100% COMPLETE

COPY FROM DISK10000 TO DISK20300 IS 100% COMPLETE

PRESS RETURN WHEN YOU WANT THE NEW UNIT TO BE CREATED

REDUCE DISK20200 DISK20300

UNMIRROR DISK10300

UNMIRROR DISK10000

ADD MIRRORSET C_MA DISK20200

ADD MIRRORSET C_MB DISK20300

ADD STRIPESSET C_ST1 C_MA C_MB

INIT C_ST1 NODESTROY

ADD UNIT D99 C_ST1

D99 HAS BEEN CREATED. IT IS A CLONE OF D98.

CLONE - NORMAL TERMINATION

Moving Stagesets

You can move a stageset from one subsystem to another without destroying its data. You also can follow the steps in this section to move a stageset to a new location within the same subsystem.



CAUTION: Move only normal stagesets. Do not move stagesets that are reconstructing or reduced, or data corruption will result.

See the release notes for the version of your controller software for information on which drives can be supported.



CAUTION: Never initialize any container or this procedure will not protect data.

Use the following procedure to move a stageset, while maintaining the data the stageset contains:

1. Show the details for the stageset you want to move. Use the following command:

```
SHOW STAGESET-NAME
```

2. Label each member with its name and PTL location.

If you do not have a stageset map for your subsystem, you can enter the LOCATE command for each member to find its PTL location. Use the following command:

```
LOCATE DISK-NAME
```

To cancel the locate command, enter the following:

```
LOCATE CANCEL
```

3. Delete the unit number shown in the “Used by” column of the SHOW *stageset-name* command. Use the following syntax:

```
DELETE UNIT-NUMBER
```

4. Delete the stageset shown in the “Name” column of the SHOW *stageset-name* command. Use the following syntax:

```
DELETE STAGESET-NAME
```

5. Delete each disk drive, one at a time, that the storage set contained. Use the following syntax:

```
DELETE DISK-NAME
```

```
DELETE DISK-NAME
```

```
DELETE DISK-NAME
```

6. Remove the disk drives and move them to their new PTL locations.
7. Again add each disk drive to the controller's list of valid devices. Use the following syntax:

```
ADD DISK DISK-NAME PTL-LOCATION
```

```
ADD DISK DISK-NAME PTL-LOCATION
```

```
ADD DISK DISK-NAME PTL-LOCATION
```

8. Recreate the storage set by adding its name to the controller's list of valid storage sets and by specifying the disk drives it contains. (Although you have to recreate the storage set from its original disks, you do not have to add the storage sets in their original order.) Use the following syntax to recreate the storage set:

```
ADD STORAGESET-NAME DISK-NAME DISK-NAME
```

9. Represent the storage set to the host by giving it a unit number the host can recognize. You can use the original unit number or create a new one. Use the following syntax:

```
ADD UNIT UNIT-NUMBER STORAGESET-NAME
```

The following example moves unit D100 to another cabinet. D100 is the RAID set RAID99 that consists of members DISK10000, DISK20000, and DISK10100.

```
DELETE D100
```

```
DELETE RAID99
```

```
DELETE DISK10000
```

```
DELETE DISK10100
```

```
DELETE DISK20000
```

```
DELETE DISK20100
```

```
ADD DISK DISK10000
```

```
ADD DISK DISK10100
```

```
ADD DISK DISK20000
```

```
ADD DISK DISK20100
```

```
ADD RAIDSET RAID99 DISK10000 DISK10100 DISK20000 DISK20100
```

```
ADD UNIT D100 RAID99
```

Appendix **A**

Subsystem Profile Templates

This appendix contains storage set profiles to copy and use to create your system profiles. It also contains an enclosure template to use to help keep track of the location of devices and storage sets in your shelves. Four (4) templates will be needed for the subsystem.

NOTE: The storage map templates for the Model 4310R and Model 4214R or 4314R reflect the disk enclosures physical location in the rack. Disk enclosures 6, 5, and 4 are stacked above the controller enclosure and disk enclosures 1, 2, and 3 are stacked below the controller enclosure.

- “Storage set Profile,” page A-2
- “Storage Map Template 1 for the BA370 Enclosure,” page A-3
- “Storage Map Template 2 for the second BA370 Enclosure,” page A-4
- “Storage Map Template 3 for the third BA370 Enclosure,” page A-5
- “Storage Map Template 4 for the Model 4214R Disk Enclosure,” page A-6
- “Storage Map Template 5 for the Model 4254 Disk Enclosure,” page A-7
- “Storage Map Template 6 for the Model 4310R Disk Enclosure,” page A-9
- “Storage Map Template 7 for the Model 4350R Disk Enclosure,” page A-11
- “Storage Map Template 8 for the Model 4314R Disk Enclosure,” page A-12
- “Storage Map Template 9 for the Model 4354R Disk Enclosure,” page A-14

StorageSet Profile

Type of StorageSet:

<input type="checkbox"/> Mirrorset	<input checked="" type="checkbox"/> RAIDset	<input type="checkbox"/> Stripeset	<input type="checkbox"/> Striped Mirrorset	<input type="checkbox"/> JBOD
------------------------------------	---	------------------------------------	--	-------------------------------

StorageSet Name

Disk Drives

Unit Number

Partitions:

Unit #	Unit #	Unit #	Unit #	Unit #	Unit #	Unit #	Unit #

RAIDset Switches:

Reconstruction Policy <input type="checkbox"/> Normal (default) <input type="checkbox"/> Fast	Reduced Membership <input type="checkbox"/> No (default) <input type="checkbox"/> Yes, missing:	Replacement Policy <input type="checkbox"/> Best performance (default) <input type="checkbox"/> Best fit <input type="checkbox"/> None
--	--	--

Mirrorset Switches:

Replacement Policy <input type="checkbox"/> Best performance (default) <input type="checkbox"/> Best fit <input type="checkbox"/> None	Copy Policy <input type="checkbox"/> Normal (default) <input type="checkbox"/> Fast	Read Source <input type="checkbox"/> Least busy (default) <input type="checkbox"/> Round robin <input type="checkbox"/> Disk drive:
--	--	---

Initialize Switches:

Chunk size <input type="checkbox"/> Automatic (default) <input type="checkbox"/> 64 blocks <input type="checkbox"/> 128 blocks <input type="checkbox"/> 256 blocks <input type="checkbox"/> Other:	Save Configuration <input type="checkbox"/> No (default) <input type="checkbox"/> Yes	Metadata <input type="checkbox"/> Destroy (default) <input type="checkbox"/> Retain
--	--	--

Unit Switches:

Caching Read caching _____ Read-ahead caching _____ Write-back caching _____ Write-through caching _____	Access by following hosts enabled _____ _____ _____ _____
---	--

Storage Map Template 1 for the BA370 Enclosure

Use this template for:

- BA370 single-enclosure subsystems
- first enclosure of multiple BA370 enclosure subsystems

	Port						
	1	2	3	4	5	6	
Power Supply	D10300	D20300	D30300	D40300	D50300	D60300	Power Supply
Power Supply	D10200	D20200	D30200	D40200	D50200	D60200	Power Supply
Power Supply	D10100	D20100	D30100	D40100	D50100	D60100	Power Supply
Power Supply	D10000	D20000	D30000	D40000	D50000	D60000	Power Supply

3
2
1
0
Targets

Storage Map Template 2 for the second BA370 Enclosure

Use this template for the second enclosure of multiple BA370 enclosure subsystems.

	Port							
	1	2	3	4	5	6		
Power Supply	D11100	D21100	D31100	D41100	D51100	D61100	Power Supply	11
Power Supply	D11000	D21000	D31000	D41000	D51000	D61000	Power Supply	10
Power Supply	D10900	D20900	D30900	D40900	D50900	D60900	Power Supply	9
Power Supply	D10800	D20800	D30800	D40800	D50800	D60800	Power Supply	8

Targets

Storage Map Template 3 for the third BA370 Enclosure

Use this template for the third enclosure of multiple BA370 enclosure subsystems.

	Port						
	1	2	3	4	5	6	
Power Supply	D11500	D21500	D31500	D41500	D51500	D61500	Power Supply
Power Supply	D11400	D21400	D31400	D41400	D51400	D61400	Power Supply
Power Supply	D11300	D21300	D31300	D41300	D51300	D61300	Power Supply
Power Supply	D11200	D21200	D31200	D41200	D51200	D61200	Power Supply

15
14
13
12

Targets

Storage Map Template 4 for the Model 4214R Disk Enclosure

Use this template for a subsystem with a three-shelf Model 4214R disk enclosure (single-bus). You can have up to six Model 4214R disk enclosures per controller shelf.

Model 4214R Disk Enclosure Shelf 1 (single-bus)														
Bay	1	2	3	4	5	6	7	8	9	10	11	12	13	14
SCSI ID	00	01	02	03	04	05	08	09	10	11	12	13	14	15
DISK ID	Disk10000	Disk10100	Disk10200	Disk10300	Disk10400	Disk10500	Disk10800	Disk10900	Disk11000	Disk11100	Disk11200	Disk11300	Disk11400	Disk11500

Model 4214R Disk Enclosure Shelf 2 (single-bus)														
Bay	1	2	3	4	5	6	7	8	9	10	11	12	13	14
SCSI ID	00	01	02	03	04	05	08	09	10	11	12	13	14	15
DISK ID	Disk20000	Disk20100	Disk20200	Disk20300	Disk20400	Disk20500	Disk20800	Disk20900	Disk21000	Disk21100	Disk21200	Disk21300	Disk21400	Disk21500

Model 4214R Disk Enclosure Shelf 3 (single-bus)														
Bay	1	2	3	4	5	6	7	8	9	10	11	12	13	14
SCSI ID	00	01	02	03	04	05	08	09	10	11	12	13	14	15
DISK ID	Disk30000	Disk30100	Disk30200	Disk30300	Disk30400	Disk30500	Disk30800	Disk30900	Disk31000	Disk31100	Disk31200	Disk31300	Disk31400	Disk31500

Storage Map Template 5 for the Model 4254 Disk Enclosure

Use this template for a subsystem with a three-shelf Model 4254 disk enclosure (dual-bus). You can have up to three Model 4254 disk enclosures per controller shelf.

Model 4254 Disk Enclosure Shelf 1 (dual-bus)														
Bus A							Bus B							
Bay	1	2	3	4	5	6	7	8	9	10	11	12	13	14
SCSI ID	00	01	02	03	04	05	08	00	01	02	03	04	05	08
DISK ID	Disk10000	Disk10100	Disk10200	Disk10300	Disk10400	Disk10500	Disk10800	Disk20000	Disk20100	Disk20200	Disk20300	Disk20400	Disk20500	Disk20800

Model 4254 Disk Enclosure Shelf 2 (dual-bus)														
Bus A							Bus B							
Bay	1	2	3	4	5	6	7	8	9	10	11	12	13	14
SCSI ID	00	01	02	03	04	05	08	00	01	02	03	04	05	08
DISK ID	Disk30000	Disk30100	Disk30200	Disk30300	Disk30400	Disk30500	Disk30800	Disk40000	Disk40100	Disk40200	Disk40300	Disk40400	Disk40500	Disk40800

continued on the following page

continued from previous page

Model 4254 Disk Enclosure Shelf 3 (dual-bus)														
Bus A							Bus B							
Bay	1	2	3	4	5	6	7	8	9	10	11	12	13	14
SCSI ID	00	01	02	03	04	05	08	00	01	02	03	04	05	08
DISK ID	Disk50000	Disk50100	Disk50200	Disk50300	Disk50400	Disk50500	Disk50800	Disk60000	Disk60100	Disk60200	Disk60300	Disk60400	Disk60500	Disk60800

Storage Map Template 6 for the Model 4310R Disk Enclosure

Use this template for a subsystem with a six-shelf Model 4310R disk enclosure (dual-bus). You can have up to six Model 4310R disk enclosures per controller shelf.

Model 4310R Disk Enclosure Shelf 6 (single-bus)

Bay	1	2	3	4	5	6	7	8	9	10
SCSI ID	00	01	02	03	04	05	08	10	11	12
DISK ID	Disk60000	Disk60100	Disk60200	Disk60300	Disk60400	Disk60500	Disk60800	Disk61000	Disk61100	Disk61200

Model 4310R Disk Enclosure Shelf 5 (single-bus)

Bay	1	2	3	4	5	6	7	8	9	10
SCSI ID	00	01	02	03	04	05	08	10	11	12
DISK ID	Disk50000	Disk50100	Disk50200	Disk50300	Disk50400	Disk50500	Disk50800	Disk51000	Disk51100	Disk51200

Model 4310R Disk Enclosure Shelf 4 (single-bus)

Bay	1	2	3	4	5	6	7	8	9	10
SCSI ID	00	01	02	03	04	05	08	10	11	12
DISK ID	Disk40000	Disk40100	Disk40200	Disk40300	Disk40400	Disk40500	Disk40800	Disk41000	Disk41100	Disk41200

continued on the following page

continued from previous page

Model 4310R Disk Enclosure Shelf 1 (single-bus)

Bay	1	2	3	4	5	6	7	8	9	10
SCSI ID	00	01	02	03	04	05	08	10	11	12
DISK ID	Disk10000	Disk10100	Disk10200	Disk10300	Disk10400	Disk10500	Disk10800	Disk11000	Disk11100	Disk11200

Model 4310R Disk Enclosure Shelf 2 (single-bus)

Bay	1	2	3	4	5	6	7	8	9	10
SCSI ID	00	01	02	03	04	05	08	10	11	12
DISK ID	Disk20000	Disk20100	Disk20200	Disk20300	Disk20400	Disk20500	Disk20800	Disk21000	Disk21100	Disk21200

Model 4310R Disk Enclosure Shelf 3 (single-bus)

Bay	1	2	3	4	5	6	7	8	9	10
SCSI ID	00	01	02	03	04	05	08	10	11	12
DISK ID	Disk30000	Disk30100	Disk30200	Disk30300	Disk30400	Disk30500	Disk30800	Disk31000	Disk31100	Disk31200

Storage Map Template 7 for the Model 4350R Disk Enclosure

Use this template for a subsystem with a three-shelf Model 4350R disk enclosure (dual-bus). You can have up to three Model 4350R disk enclosures per controller shelf.

Model 4310R Disk Enclosure Shelf 6 (single-bus)

Bay	1	2	3	4	5	6	7	8	9	10
SCSI ID	00	01	02	03	04	05	08	10	11	12
DISK ID	Disk60000	Disk60100	Disk60200	Disk60300	Disk60400	Disk60500	Disk60800	Disk61000	Disk61100	Disk61200

Model 4310R Disk Enclosure Shelf 5 (single-bus)

Bay	1	2	3	4	5	6	7	8	9	10
SCSI ID	00	01	02	03	04	05	08	10	11	12
DISK ID	Disk50000	Disk50100	Disk50200	Disk50300	Disk50400	Disk50500	Disk50800	Disk51000	Disk51100	Disk51200

Model 4310R Disk Enclosure Shelf 4 (single-bus)

Bay	1	2	3	4	5	6	7	8	9	10
SCSI ID	00	01	02	03	04	05	08	10	11	12
DISK ID	Disk40000	Disk40100	Disk40200	Disk40300	Disk40400	Disk40500	Disk40800	Disk41000	Disk41100	Disk41200

Storage Map Template 8 for the Model 4314R Disk Enclosure

Use this template for a subsystem with a six-shelf Model 4314R disk enclosure. You can have a maximum of six Model 4314R disk enclosures with each Model 2200 controller enclosure.

Model 4314R Disk Enclosure Shelf 6 (single-bus)

Bay	1	2	3	4	5	6	7	8	9	10	11	12	13	14
SCSI ID	00	01	02	03	04	05	08	09	10	11	12	13	14	15
DISK ID	Disk60000	Disk60100	Disk60200	Disk60300	Disk60400	Disk60500	Disk60800	Disk60900	Disk61000	Disk61100	Disk61200	Disk61300	Disk61400	Disk61500

Model 4314R Disk Enclosure Shelf 5 (single-bus)

Bay	1	2	3	4	5	6	7	8	9	10	11	12	13	14
SCSI ID	00	01	02	03	04	05	08	09	10	11	12	13	14	15
DISK ID	Disk50000	Disk50100	Disk50200	Disk50300	Disk50400	Disk50500	Disk50800	Disk50900	Disk51000	Disk51100	Disk51200	Disk51300	Disk51500	Disk51500

Model 4314R Disk Enclosure Shelf 4 (single-bus)

Bay	1	2	3	4	5	6	7	8	9	10	11	12	13	14
SCSI ID	00	01	02	03	04	05	08	09	10	11	12	13	14	15
DISK ID	Disk40000	Disk40100	Disk40200	Disk40300	Disk40400	Disk40500	Disk40800	Disk40900	Disk41000	Disk41100	Disk41200	Disk41300	Disk41400	Disk41500

continued from previous page

Model 4314R Disk Enclosure Shelf 1 (single-bus)

Bay	1	2	3	4	5	6	7	8	9	10	11	12	13	14
SCSI ID	00	01	02	03	04	05	08	09	10	11	12	13	14	15
DISK ID	Disk10000	Disk10100	Disk10200	Disk10300	Disk10400	Disk10500	Disk10800	Disk10900	Disk11000	Disk11100	Disk11200	Disk11300	Disk11400	Disk11500

Model 4314R Disk Enclosure Shelf 2 (single-bus)

Bay	1	2	3	4	5	6	7	8	9	10	11	12	13	14
SCSI ID	00	01	02	03	04	05	08	09	10	11	12	13	14	15
DISK ID	Disk20000	Disk20100	Disk20200	Disk20300	Disk20400	Disk20500	Disk20800	Disk20900	Disk21000	Disk21100	Disk21200	Disk21300	Disk21400	Disk21500

Model 4314R Disk Enclosure Shelf 3 (single-bus)

Bay	1	2	3	4	5	6	7	8	9	10	11	12	13	14
SCSI ID	00	01	02	03	04	05	08	09	10	11	12	13	14	15
DISK ID	Disk30000	Disk30100	Disk30200	Disk30300	Disk30400	Disk30500	Disk30800	Disk30900	Disk31000	Disk31100	Disk31200	Disk31300	Disk31400	Disk31500

Storage Map Template 9 for the Model 4354R Disk Enclosure

Use this template for a subsystem with a three-shelf Model 4354R disk enclosure (dual-bus). You can have up to three Model 4350R disk enclosures per controller shelf.

Model 4354R Disk Enclosure Shelf 1 (dual-bus)

	SCSI Bus A							SCSI Bus B						
Bay	1	2	3	4	5	6	7	8	9	10	11	12	13	14
SCSI ID	00	01	02	03	04	05	08	00	01	02	03	04	05	08
DISK ID	Disk10000	Disk10100	Disk10200	Disk10300	Disk10400	Disk10500	Disk10800	Disk20000	Disk20100	Disk20200	Disk20300	Disk20400	Disk20500	Disk20800

Model 4354R Disk Enclosure Shelf 2 (dual-bus)

	SCSI Bus A							SCSI Bus B						
Bay	1	2	3	4	5	6	7	8	9	10	11	12	13	14
SCSI ID	00	01	02	03	04	05	08	00	01	02	03	04	05	08
DISK ID	Disk30000	Disk30100	Disk30200	Disk30300	Disk30400	Disk30500	Disk30800	Disk40000	Disk40100	Disk40200	Disk40300	Disk40400	Disk40500	Disk40800

Model 4354R Disk Enclosure Shelf 3 (dual-bus)

	SCSI Bus A							SCSI Bus B						
Bay	1	2	3	4	5	6	7	8	9	10	11	12	13	14
SCSI ID	00	01	02	03	04	05	08	00	01	02	03	04	05	08
DISK ID	Disk50000	Disk50100	Disk50200	Disk50300	Disk50400	Disk50500	Disk50800	Disk60000	Disk60100	Disk60200	Disk60300	Disk60400	Disk60500	Disk60800

Installing, Configuring, and Removing the Client

The following information is included in this appendix:

- “Why Install the Client?,” page B-1
- “Before You Install the Client,” page B-2
- “Installing the Client,” page B-2
- “Troubleshooting the Client Installation,” page B-3
- “Adding the Storage Subsystem and its Host to the Navigation Tree,” page B-5
- “Removing the Command Console Client,” page B-7
- “Where to Find Additional Information,” page B-8

Why Install the Client?

The Client monitors and manages a storage subsystem by performing the following tasks:

- Create mirrored device group (RAID 1)
- Create striped device group (RAID 0)
- Create striped mirrored device group (RAID 0+1)
- Create striped parity device group (3/5)
- Create an individual device (JBOD)
- Monitor many subsystems at once
- Set up pager notification

Before You Install the Client

1. Verify you are logged into an account that is a member of the administrator group.
2. Check the software product description that came with the software for a list of supported hardware.
3. Verify that you have the SNMP service installed on the computer. SNMP must be installed on the computer for this software to work properly. The Client software uses SNMP to receive traps from the Agent. The SNMP service is available on the Windows NT or Windows 2000 installation CD-ROM. To verify that you have the SNMP service:
 - ❑ For Windows NT, double-click Services in *Start > Settings > Control Panel*. The entry for SNMP is shown in this window. If you install the SNMP service and you already have Windows NT Service Pack 6A on the computer, reinstall the service pack after installing the SNMP service.
 - ❑ For Windows 2000, click *Start > Settings > Control Panel > Administrative Tools > Component Services*. The entry for SNMP is shown in the Component Services window.
4. Read the release notes.
5. Read "Troubleshooting the Client Installation" in this appendix.
6. If you have the Command Console Client open, exit the Command Console Client.
7. If you have Command Console Client version 1.1b or earlier, remove the program with the Windows Add/Remove Programs utility.
8. If you have a previous version of Command Console, you can save the Navigation Tree configuration by copying the *SWCC2.MDB* file to another directory. After you have installed the product, move *SWCC2.MDB* to the directory to which you installed SWCC.
9. Install the HS-Series Agent. For more information, see Chapter 4.

Installing the Client

1. Insert the CD-ROM into a computer running Windows 2000 with Service Pack 1 or Windows NT 4.0 (Intel) with Service Pack 6A.
2. Using Microsoft Windows Explorer, navigate to:
`\\swcc`
Double click *SETUP.EXE*

3. Select HSG80 Controller and click **Next**.

NOTE: If the computer does not find a previous installation, it will install the SWCC Navigation Window and the CLI Window.

4. Follow the instructions on the screen. After you install the software, the Asynchronous Event Service (AES) starts. AES is a service that runs in the background. It collects and passes traps from the subsystems to the Navigation Tree and to individual pagers (for example, to show that a disk has failed). AES needs to be running for the client system to receive updates.

NOTE: For more information on AES, see *Compaq StorageWorks Command Console Version 2.4 User Guide*.

Troubleshooting the Client Installation

This section provides information on how to resolve some of the problems that may appear when installing the Client software:

- Invalid Network Port Assignments During Installation
- “There is no disk in the drive” Message

Invalid Network Port Assignments During Installation

SWCC Clients and Agents communicate by using sockets. The SWCC installation attempts to add entries into each system list of services (services file or for UCX, the local services database). If the SWCC installation finds an entry in the local services file with the same name as the one it wants to add, it assumes the one in the file is correct.

The SWCC installation may display a message, stating that it cannot upgrade the services file. This happens if it finds an entry in the local services file with the same number as the one it wants to add, but with a different name. In that case, appropriate port numbers must be obtained for the network and added manually to the services file.

There are two default port numbers, one for Command Console (4998) and the other for the device-specific Agent and Client software, such as the Fibre Channel Interconnect Client and Agent (4989). There are two exceptions. The following software has two default port numbers:

- The KZPCC Agent and Client, (4991 and 4985)
- The RA200 Agent and Client, (4997 and 4995)

If the Network Information Services (NIS) are being used to provide named port lookup services, contact the network administrator to add the correct ports.

The following shows how the network port assignments appear in the services file:

spgui	4998/tcp	#Command Console
ccdevmgt	4993/tcp	#Device Management Client and Agent
kzpccconnectport	4991/tcp	#KZPCC Client and Agent
kzpccdcoveryport	4985/tcp	#KZPCC Client and Agent
ccfabric	4989/tcp	#Fibre Channel Interconnect Agent
spagent	4999/tcp	#HS-Series Client and Agent
spagent3	4994/tcp	#HSZ22 Client and Agent
ccagent	4997/tcp	#RA200 Client and Agent
spagent2	4995/tcp	#RA200 Client and Agent

“There is no disk in the drive” Message

When you install the Command Console Client, the software checks the shortcuts on the desktop and in the Start menu. The installation will check the shortcuts of all users for that computer, even if they are not currently logged on. You may receive an error message if any of these shortcuts point to empty floppy drives, empty CD-ROM drives, or missing removable disks. Do one of the following:

- Ignore the error message by clicking **Ignore**.
- Replace the removable disks, and place a disk in the floppy drive and a CD-ROM in the CD-ROM drive. Then, click **Retry**.

Adding the Storage Subsystem and its Host to the Navigation Tree

The Navigation Tree enables you to manage storage over the network by using the Storage Window. If you plan to use pager notification, you must add the storage subsystem to the Navigation Tree.

1. Verify that you have properly installed and configured the HS-Series Agent on the storage subsystem host.
2. Click *Start > Programs > Command Console > StorageWorks Command Console*. Client displays the Navigation Window. The Navigation Window lets you monitor and manage many storage subsystems over the network.



Figure B-1. Navigation window

3. Click *File > Add System*. The Add System window appears.
4. Type the host name or its TCP/IP address and click *Apply*.
5. Click *Close*.



Figure B-2. Navigation window showing storage host system "Atlanta"

6. Click the plus sign to expand the host icon. When expanded, the Navigation Window displays an icon for the storage subsystem. To access the Storage Window for the subsystem, double-click the Storage Window icon.



Figure B-3. Navigation window showing expanded "Atlanta" host icon

NOTE: You can create virtual disks by using the Storage Window. For more information on the Storage Window, refer to *Compaq StorageWorks Command Console Version 2.4 User Guide*.

Removing the Command Console Client

Before you remove the Command Console Client (CCL) from the computer, remove AES. This will prevent the system from reporting that a service failed to start every time the system is restarted. Steps 2 through 5 describe how to remove the CCL.

NOTE: When you remove the CCL, the *SWCC2.MDB* file is deleted. This file contains the Navigation Tree configuration. If you want to save this information, move the file to another directory.

1. Click *Start > Programs > Command Prompt* and change to the directory to which you installed the CCL.
2. Enter the following command:

```
C:\Program Files\Compaq\SWCC> AsyncEventService -remove
```
3. Do one of the following:
 - On Windows NT 4.0, click *Start > Settings > Control Panel*, and double-click the Add/Remove Programs icon in the Control Panel. The Add/Remove Program Properties window appears.
 - On Windows 2000, click *Start > Settings > Control Panel > Add/Remove Programs*. The Add/Remove Program window appears.
4. Select Command Console in the window.
5. Do one of the following:
 - On Windows NT 4.0, click *Add/Remove*.
 - On Windows 2000, click *Change/Remove*.
6. Follow the instructions on the screen.

NOTE: This procedure removes only the Command Console Client (SWCC Navigation Window). You can remove the HSG80 Client by using the Add/Remove program.

Where to Find Additional Information

You can find additional information about SWCC by referring to the online Help and to *Compaq StorageWorks Command Console Version 2.4 User Guide*.

About the User Guide

Compaq StorageWorks Command Console Version 2.4 User Guide contains additional information on how to use SWCC. Some of the topics in the user guide are the following:

- About AES
- Adding Devices
- Adding Virtual Disks
- Setting Up Pager Notification
- How to Integrate SWCC with Compaq Insight Manager
- Troubleshooting Information

About the Online Help

Most of the information about the Client is provided in the online Help. Online Help is provided in two places:

- Navigation Window – Online Help provides information on pager notification and a tour of the Command Console Client, in addition to information on how to add a system to the Navigation Tree.
- Storage Window – Online Help provides detailed information about the Storage Window, such as how to create virtual disks.

Glossary

This glossary defines terms pertaining to the ACS solution software. It is not a comprehensive glossary of computer terms.

adapter	A device that converts the protocol and hardware interface of one bus type into another without changing the function of the bus.
ACS	<i>See</i> array controller software.
AL_PA	<i>See</i> arbitrated loop physical address.
ANSI	Pronounced “ann-see.” Acronym for the American National Standards Institute. An organization who develops standards used voluntarily by many manufacturers within the USA. ANSI is not a government agency.
arbitrated loop physical address	Abbreviated AL_PA. A one-byte value used to identify a port in an Arbitrated Loop topology.
array controller	<i>See</i> controller.
array controller software	Abbreviated ACS. Software contained on a removable ROM program card that provides the operating system for the array controller.
asynchronous	Pertaining to events that are scheduled as the result of a signal asking for the event; pertaining to that which is without any specified time relation. <i>See also</i> synchronous.
autospare	A controller feature that automatically replaces a failed disk drive. To aid the controller in automatically replacing failed disk drives, you can enable the AUTOSPARE switch for the failedset causing physically replaced disk drives to be automatically placed into the spareset. Also called “autonewspare.”
bad block	A data block that contains a physical defect.

bad block replacement	Abbreviated BBR. A replacement routine that substitutes defect-free disk blocks for those found to have defects. This process takes place in the controller, transparent to the host.
backplane	The electronic printed circuit board into which you plug subsystem devices—for example, the SBB or power supply.
BBR	<i>See</i> bad block replacement.
BIST	<i>See</i> built-in self-test.
bit	A single binary digit having a value of either 0 or 1. A bit is the smallest unit of data a computer can process.
block	Also called a sector. The smallest collection of consecutive bytes addressable on a disk drive. In integrated storage elements, a block contains 512 bytes of data, error codes, flags, and the block address header.
bootstrapping	A method used to bring a system or device into a defined state by means of its own action. For example, a machine routine whose first few instructions are enough to bring the rest of the routine into the computer from an input device.
built-in self-test	A diagnostic test performed by the array controller software on the controller policy processor.
byte	A binary character string made up of 8 bits operated on as a unit.
cache memory	A portion of memory used to accelerate read and write operations.
CDU	Cable distribution unit. The power entry device for StorageWorks cabinets. The CDU provides the connections necessary to distribute power to the cabinet shelves and fans.
channel	An interface that allows high speed transfer of large amounts of data. Another term for a SCSI bus. <i>See also</i> SCSI.
chunk	A block of data written by the host.
chunk size	The number of data blocks, assigned by a system administrator, written to the primary RAIDset or stripeset member before the remaining data blocks are written to the next RAIDset or stripeset member.
CLCP	An abbreviation for code-load code-patch utility. This utility is used to upgrade the controller and EMU software. It can also be used to patch the controller software.

coax	A two-conductor wire in which one conductor completely wraps the other with the two separated by insulation.
cold swap	A method of device replacement that requires the entire subsystem to be turned off before the device can be replaced. <i>See also</i> hot swap and warm swap.
command line interpreter	(CLI) The configuration interface to operate the controller software.
concat commands	Concat commands implement storageset expansion features.
configuration file	A file that contains a representation of a storage subsystem configuration.
container	1) Any entity that is capable of storing data, whether it is a physical device or a group of physical devices. (2) A virtual, internal controller structure representing either a single disk or a group of disk drives linked as a storageset. Stripesets and mirrorsets are examples of storageset containers the controller uses to create units.
controller	A hardware device that, with proprietary software, facilitates communications between a host and one or more devices organized in an array. The HSG80 family controllers are examples of array controllers.
copying	A state in which data to be copied to the mirrorset is inconsistent with other members of the mirrorset. <i>See also</i> normalizing.
copying member	Any member that joins the mirrorset after the mirrorset is created is regarded as a copying member. Once all the data from the normal member (or members) is copied to a normalizing or copying member, the copying member then becomes a normal member. <i>See also</i> normalizing member.
CSR	An acronym for control and status register.
DAEMON	Pronounced “demon.” A program usually associated with a UNIX systems that performs a utility (housekeeping or maintenance) function without being requested or even known of by the user. A daemon is a diagnostic and execution monitor.
data center cabinet	A generic reference to large Compaq subsystem cabinets, such as the cabinets in which StorageWorks components can be mounted.

data striping	The process of segmenting logically sequential data, such as a single file, so that segments can be written to multiple physical devices (usually disk drives) in a round-robin fashion. This technique is useful if the processor is capable of reading or writing data faster than a single disk can supply or accept the data. While data is being transferred from the first disk, the second disk can locate the next segment.
device	<i>See</i> node and peripheral device.
differential I/O module	A 16-bit I/O module with SCSI bus converter circuitry for extending a differential SCSI bus. <i>See also</i> I/O module.
differential SCSI bus	A bus in which a signal level is determined by the potential difference between two wires. A differential bus is more robust and less subject to electrical noise than is a single-ended bus.
DIMM	Dual inline Memory Module.
dirty data	The write-back cached data that has not been written to storage media, even though the host operation processing the data has completed.
DMA	Direct Memory Access.
DOC	DWZZA-On-a-Chip. ASCSI bus extender chip used to connect a SCSI bus in an expansion cabinet to the corresponding SCSI bus in another cabinet.
driver	A hardware device or a program that controls or regulates another device. For example, a device driver is a driver developed for a specific device that allows a computer to operate with the device, such as a printer or a disk drive.
dual-redundant configuration	A controller configuration consisting of two active controllers operating as a single controller. If one controller fails, the other controller assumes control of the failing controller devices.
dual-simplex	A communications protocol that allows simultaneous transmission in both directions in a link, usually with no flow control.
DUART	Dual universal asynchronous receiver and transmitter. An integrated circuit containing two serial, asynchronous transceiver circuits.
ECB	External cache battery. The unit that supplies backup power to the cache module in the event the primary power source fails or is interrupted.
ECC	Error checking and correction.
EDC	Error detection code.

EIA	The abbreviation for Electronic Industries Association. EIA is a standards organization specializing in the electrical and functional characteristics of interface equipment.
EMU	Environmental monitoring unit. A unit that provides increased protection against catastrophic failures. Some subsystem enclosures include an EMU which works with the controller to detect conditions such as failed power supplies, failed blowers, elevated temperatures, and external air sense faults. The EMU also controls certain cabinet hardware including DOC chips, alarms, and fan speeds.
ESD	Electrostatic discharge. The discharge of potentially harmful static electrical voltage as a result of improper grounding.
extended subsystem	A subsystem in which two cabinets are connected to the primary cabinet.
external cache battery	<i>See</i> ECB.
F_Port	A port in a fabric where an N_Port or NL_Port may attach.
fabric	A group of interconnections between ports that includes a fabric element.
failedset	A group of failed mirrorset or RAIDset devices automatically created by the controller.
failover	The process that takes place when one controller in a dual-redundant configuration assumes the workload of a failed companion controller. Failover continues until the failed controller is repaired or replaced.
FC-AL	The Fibre Channel Arbitrated Loop standard. <i>See Fibre Channel.</i>
FC-ATM	ATM AAL5 over Fibre Channel
FC-FG	Fibre Channel Fabric Generic Requirements
FG-FP	Fibre Channel Framing Protocol (HIPPI on FC)
FC-GS-1	Fibre Channel Generic Services-1
FC-GS-2	Fibre Channel Generic Services-2
FC-IG	Fibre Channel Implementation Guide
FC-LE	Fibre Channel Link Encapsulation (ISO 8802.2)

FC–PH	The Fibre Channel Physical and Signaling standard.
FC–SB	Fibre Channel Single Byte Command Code Set
FC–SW	Fibre Channel Switched Topology and Switch Controls
FCC	Federal Communications Commission. The federal agency responsible for establishing standards and approving electronic devices within the United States.
FCC Class A	This certification label appears on electronic devices that can only be used in a commercial environment within the United States.
FCC Class B	This certification label appears on electronic devices that can be used in either a home or a commercial environment within the United States.
FCP	The mapping of SCSI-3 operations to Fibre Channel.
FDDI	Fiber Distributed Data Interface. An ANSI standard for 100 megabaud transmission over fiber optic cable.
FD SCSI	The fast, narrow, differential SCSI bus with an 8-bit data transfer rate of 10 MB/s. <i>See also</i> FWD SCSI and SCSI.
fiber	A fiber or optical strand. Spelled <i>fib</i> re in Fibre Channel.
fiber optic cable	A transmission medium designed to transmit digital signals in the form of pulses of light. Fiber optic cable is noted for its properties of electrical isolation and resistance to electrostatic contamination.
Fibre Channel	A high speed, high-bandwidth serial protocol for channels and networks that interconnect over twisted pair wires, coaxial cable or fiber optic cable. The Fibre Channel Switched (FC-SW) (fabric) offers up to 16 million ports with cable lengths of up to 10 kilometers. The Fibre Channel Arbitrated Loop (FC-AL) topology offers speeds of up to 100 Mbytes/seconds and up to 127 nodes, all connected in serial. In contrast to SCSI technology, Fibre Channel does not require ID switches or terminators. The FC-AL loop may be connected to a Fibre Channel fabric for connection to other nodes.
fib re channel topology	An interconnection scheme that allows multiple Fibre Channel ports to communicate with each other. For example, point-to-point, Arbitrated Loop, and switched fabric are all Fibre Channel topologies.
FL_Port	A port in a fabric where N_Port or an NL_Port may be connected.
flush	The act of writing dirty data from cache to a storage media.

FMU	Fault management utility.
forced errors	A data bit indicating a corresponding logical data block contains unrecoverable data.
frame	An invisible unit used to transfer information in Fibre Channel.
FRU	Field replaceable unit. A hardware component that can be replaced at the customer location by Compaq service personnel or qualified customer service personnel.
FRUTIL	Field Replacement utility.
full duplex (n)	A communications system in which there is a capability for 2-way transmission and acceptance between two sites at the same time.
full duplex (adj)	Pertaining to a communications method in which data can be transmitted and received at the same time.
FWD SCSI	A fast, wide, differential SCSI bus with a maximum 16-bit data transfer rate of 20 MB/s. <i>See also</i> SCSI and FD SCSI.
GBIC	Gigabit Interface Converter. GBICs convert electrical signals to optical signals (and vice-versa.) They are inserted into the ports of the Fibre Channel switch and hold the Fibre Channel cables.
GLM	Gigabit link module
giga	A prefix indicating a billion (10^9) units, as in gigabaud or gigabyte.
gigabaud	An encoded bit transmission rate of one billion (10^9) bits per second.
gigabyte	A value normally associated with a disk drives storage capacity, meaning a billion (10^9) bytes. The decimal value 1024 is usually used for one thousand.
half-duplex (adj)	Pertaining to a communications system in which data can be either transmitted or received but only in one direction at one time.
hard address	The AL_PA which an NL_Port attempts to acquire during loop initialization.
heterogeneous host support	Also called <i>noncooperating host support</i> .
HIPPI-FC	Fibre Channel over HIPPI
host	The primary or controlling computer to which a storage subsystem is attached.

host adapter	A device that connects a host system to a SCSI bus. The host adapter usually performs the lowest layers of the SCSI protocol. This function may be logically and physically integrated into the host system.
hot disks	A disk containing multiple hot spots. Hot disks occur when the workload is poorly distributed across storage devices which prevents optimum subsystem performance. <i>See also</i> hot spots.
hot spots	A portion of a disk drive frequently accessed by the host. Because the data being accessed is concentrated in one area, rather than spread across an array of disks providing parallel access, I/O performance is significantly reduced. <i>See also</i> hot disks.
hot swap	A method of device replacement that allows normal I/O activity on a device bus to remain active during device removal and insertion. The device being removed or inserted is the only device that cannot perform operations during this process. <i>See also</i> cold swap and warm swap.
hub	A device (concentrator) which performs some or all of the following functions: <ul style="list-style-type: none">■ Automatic insertion of operational loop devices without disrupting the existing configuration.■ Automatic removal of failed loop devices without impacting the existing configuration.■ Provides a centralized (star) wiring configuration and maintenance point.■ Provides central monitoring and management.
IBR	Initial Boot Record.
ILF	Illegal function.
INIT	Initialize input and output.
initiator	A SCSI device that requests an I/O process to be performed by another SCSI device, namely, the SCSI target. The controller is the initiator on the device bus. The host is the initiator on the host bus.
instance code	A four-byte value displayed in most text error messages and issued by the controller when a subsystem error occurs. The instance code indicates when during software processing the error was detected.
interface	A set of protocols used between components, such as cables, connectors, and signal levels.

I/O	Refers to input and output functions.
I/O driver	The set of code in the kernel that handles the physical I/O to a device. This is implemented as a fork process. Same as driver.
I/O interface	<i>See</i> interface.
I/O module	A 16-bit SBB shelf device that integrates the SBB shelf with either an 8-bit single ended, 16-bit single-ended, or 16-bit differential SCSI bus.
I/O operation	The process of requesting a transfer of data from a peripheral device to memory (or visa versa), the actual transfer of the data, and the processing and overlaying activity to make both of those happen.
IPI	Intelligent Peripheral Interface. An ANSI standard for controlling peripheral devices by a host computer.
IPI-3 Disk	Intelligent Peripheral Interface Level 3 for Disk
IPI-3 Tape	Intelligent Peripheral Interface Level 3 for Tape
JBOD	Just a bunch of disks. A term used to describe a group of single-device logical units.
kernel	The most privileged processor access mode.
LBN	Logical Block Number.
L_port	A node or fabric port capable of performing arbitrated loop functions and protocols. NL_Ports and FL_Ports are loop-capable ports.
LED	Light Emitting Diode.
link	A connection between two Fibre Channel ports consisting of a transmit fibre and a receive fibre.
local connection	A connection to the subsystem using either its serial maintenance port or the host SCSI bus. A local connection enables you to connect to one subsystem controller within the physical range of the serial or host SCSI cable.
local terminal	A terminal plugged into the EIA-423 maintenance port located on the front bezel of the controller. <i>See also</i> maintenance terminal.
logical bus	A single-ended bus connected to a differential bus by a SCSI bus signal converter.

logical unit	A physical or virtual device addressable through a target ID number. LUNs use their target bus connection to communicate on the SCSI bus.
logical unit number	A value that identifies a specific logical unit belonging to a SCSI target ID number. A number associated with a physical device unit during a task I/O operations. Each task in the system must establish its own correspondence between logical unit numbers and physical devices.
logon	Also called login. A procedure whereby a participant, either a person or network connection, is identified as being an authorized network participant.
loop	<i>See</i> arbitrated loop.
loop_ID	A seven-bit value numbered contiguously from zero to 126-decimal and represent the 127 legal AL_PA values on a loop (not all of the 256 hex values are allowed as AL_PA values per FC-AL.)
loop tenancy	The period of time between the following events: when a port wins loop arbitration and when the port returns to a monitoring state.
L_Port	A node or fabric port capable of performing Arbitrated Loop functions and protocols. NL_Ports and FL_Ports are loop-capable ports.
LRU	Least recently used. A cache term used to describe the block replacement policy for read cache.
Mbps	Approximately one million (10^6) bits per second—that is, megabits per second.
MBps	Approximately one million (10^6) bytes per second—that is, megabytes per second.
maintenance terminal	An EIA-423-compatible terminal used with the controller. This terminal is used to identify the controller, enable host paths, enter configuration information, and check the controller status. The maintenance terminal is not required for normal operations. <i>See also</i> local terminal.
member	A container that is a storage element in a RAID array.

metadata	The data written to a disk for the purposes of controller administration. Metadata improves error detection and media defect management for the disk drive. It is also used to support storage set configuration and partitioning. Nontransportable disks also contain metadata to indicate they are uniquely configured for StorageWorks environments. Metadata can be thought of as “data about data.”
mirroring	The act of creating an exact copy or image of data.
mirrored write-back caching	A method of caching data that maintains two copies of the cached data. The copy is available if either cache module fails.
mirrorset	<i>See</i> RAID level 1.
MIST	Module Integrity Self-Test.
N_port	A port attached to a node for use with point-to-point topology or fabric topology.
NL_port	A port attached to a node for use in all topologies.
network	In data communication, a configuration in which two or more terminals or devices are connected to enable information transfer.
node	In data communications, the point at which one or more functional units connect transmission lines.
Non-L_Port	A Node of Fabric port that is not capable of performing the Arbitrated Loop functions and protocols. N_Ports and F_Ports loop-capable ports.
non-participating mode	A mode within an L_Port that inhibits the port from participating in loop activities. L_Ports in this mode continue to retransmit received transmission words but are not permitted to arbitrate or originate frames. An L_Port in non-participating mode may or may not have an AL_PA. <i>See also</i> participating mode.
nominal membership	The desired number of mirrorset members when the mirrorset is fully populated with active devices. If a member is removed from a mirrorset, the actual number of members may fall below the “nominal” membership.
node	In data communications, the point at which one or more functional units connect transmission lines. In Fibre Channel, a device that has at least one N_Port or NL_Port.

nonredundant controller configuration	(1) A single controller configuration. (2) A controller configuration that does not include a second controller.
normal member	A mirrorset member that, block-for-block, contains the same data as other normal members within the mirrorset. Read requests from the host are always satisfied by normal members.
normalizing	Normalizing is a state in which, block-for-block, data written by the host to a mirrorset member is consistent with the data on other normal and normalizing members. The normalizing state exists only after a mirrorset is initialized. Therefore, no customer data is on the mirrorset.
normalizing member	A mirrorset member whose contents are the same as all other normal and normalizing members for data that has been written since the mirrorset was created or lost cache data was cleared. A normalizing member is created by a normal member when either all of the normal members fail or all of the normal members are removed from the mirrorset. <i>See also</i> copying member.
NVM	Non-Volatile Memory. A type of memory where the contents survive power loss. Also sometimes referred to as NVMEM.
OCP	Operator control panel. The control or indicator panel associated with a device. The OCP is usually mounted on the device and is accessible to the operator.
other controller	The controller in a dual-redundant pair that is connected to the controller serving the current CLI session. <i>See also</i> this controller.
outbound fiber	One fiber in a link that carries information away from a port.
parallel data transmission	A data communication technique in which more than one code element (for example, bit) of each byte is sent or received simultaneously.
parity	A method of checking if binary numbers or characters are correct by counting the ONE bits. In odd parity, the total number of ONE bits must be odd; in even parity, the total number of ONE bits must be even.
parity bit	A binary digit added to a group of bits that checks to see if errors exist in the transmission.
parity check	A method of detecting errors when data is sent over a communications line. With even parity, the number of ones in a set of binary data should be even. With odd parity, the number of ones should be odd.

participating mode	A mode within an L_Port that allows the port to participate in loop activities. A port must have a valid AL_PA to be in participating mode.
PCM	Polycenter Console Manager.
PCMCIA	Personal Computer Memory Card Industry Association. An international association formed to promote a common standard for PC card-based peripherals to be plugged into notebook computers. The card commonly known as a PCMCIA card is about the size of a credit card.
parity	A method of checking if binary numbers or characters are correct by counting the ONE bits. In odd parity, the total number of ONE bits must be odd; in even parity, the total number of ONE bits must be even. Parity information can be used to correct corrupted data. RAIDsets use parity to improve the availability of data.
parity bit	A binary digit added to a group of bits that checks to see if there are errors in the transmission.
parity RAID	<i>See</i> RAIDset.
partition	A logical division of a container, represented to the host as a logical unit.
peripheral device	Any unit, distinct from the CPU and physical memory, that can provide the system with input or accept any output from it. Terminals, printers, tape drives, and disks are peripheral devices.
point-to-point connection	A network configuration in which a connection is established between two, and only two, terminal installations. The connection may include switching facilities.
port	(1) In general terms, a logical channel in a communications system. (2) The hardware and software used to connect a host controller to a communications bus, such as a SCSI bus or serial bus. Regarding the controller, the port is (1) the logical route for data in and out of a controller that can contain one or more channels, all of which contain the same type of data. (2) The hardware and software that connects a controller to a SCSI device.
port_name	A 64-bit unique identifier assigned to each Fibre Channel port. The Port_Name is communicated during the logon and port discovery process.
preferred address	The AL_PA which an NL_Port attempts to acquire first during initialization.

primary cabinet	The primary cabinet is the subsystem enclosure that contains the controllers, cache modules, external cache batteries, and the PVA module.
private NL_Port	An NL_Port which does not attempt login with the fabric and only communicates with NL_Ports on the same loop.
program card	The PCMCIA card containing the controller operating software.
protocol	The conventions or rules for the format and timing of messages sent and received.
PTL	Port-Target-LUN. The controller method of locating a device on the controller device bus.
PVA module	Power Verification and Addressing module.
quiesce	The act of rendering bus activity inactive or dormant. For example, “quiesce the SCSI bus operations during a device warm-swap.”
RAID	Redundant Array of Independent Disks. Represents multiple levels of storage access developed to improve performance or availability or both.
RAID level 0	A RAID storage set that stripes data across an array of disk drives. A single logical disk spans multiple physical disks, enabling parallel data processing for increased I/O performance. While the performance characteristics of RAID level 0 is excellent, this RAID level is the only one that does not provide redundancy. Raid level 0 storage sets are sometimes referred to as stripesets.
RAID level 0+1	A RAID storage set that stripes data across an array of disks (RAID level 0) and mirrors the striped data (RAID level 1) to provide high I/O performance and high availability. This RAID level is alternatively called a striped mirrorset.
RAID level 1	A RAID storage set of two or more physical disks that maintain a complete and independent copy of the entire virtual disk's data. This type of storage set has the advantage of being highly reliable and extremely tolerant of device failure. Raid level 1 storage sets are sometimes referred to as mirrorsets.
RAID level 3	A RAID storage set that transfers data parallel across the array disk drives a byte at a time, causing individual blocks of data to be spread over several disks serving as one enormous virtual disk. A separate redundant check disk for the entire array stores parity on a dedicated disk drive within the storage set. <i>See also</i> RAID level 5.

RAID level 5	A RAID storageset that, unlike RAID level 3, stores the parity information across all of the disk drives within the storageset. <i>See also</i> RAID level 3.
RAID level 3/5	A RAID storageset that stripes data and parity across three or more members in a disk array. A RAIDset combines the best characteristics of RAID level 3 and RAID level 5. A RAIDset is the best choice for most applications with small to medium I/O requests, unless the application is write intensive. A RAIDset is sometimes called parity RAID.
RAIDset	<i>See</i> RAID level 3/5.
RAM	Random access memory.
read ahead caching	A caching technique for improving performance of synchronous sequential reads by prefetching data from disk.
read caching	A cache management method used to decrease the subsystem response time to a read request by allowing the controller to satisfy the request from the cache memory rather than from the disk drives.
reconstruction	The process of regenerating the contents of a failed member data. The reconstruct process writes the data to a spareset disk and incorporates the spareset disk into the mirrorset, striped mirrorset, or RAIDset from which the failed member came. <i>See also</i> regeneration.
reduced	Indicates that a mirrorset or RAIDset is missing one member because the member has failed or has been physically removed.
redundancy	The provision of multiple interchangeable components to perform a single function in order to cope with failures and errors. A RAIDset is considered to be redundant when user data is recorded directly to one member and all of the other members include associated parity information.
regeneration	(1) The process of calculating missing data from redundant data. (2) The process of recreating a portion of the data from a failing or failed drive using the data and parity information from the other members within the storageset. The regeneration of an entire RAIDset member is called reconstruction. <i>See also</i> reconstruction.
request rate	The rate at which requests are arriving at a servicing entity.
RFI	Radio frequency interference. The disturbance of a signal by an unwanted radio signal or frequency.

replacement policy	The policy specified by a switch with the SET FAILEDSET command indicating whether a failed disk from a mirrorset or RAIDset is to be automatically replaced with a disk from the spareset. The two switch choices are AUTOSPARE and NOAUTOSPARE.
SBB	StorageWorks building block. (1) A modular carrier plus the interface required to mount the carrier into a standard StorageWorks shelf. (2) any device conforming to shelf mechanical and electrical standards installed in a 3.5-inch or 5.25-inch carrier, whether it is a storage device or power supply.
SCSI	Small computer system interface. (1) An ANSI interface standard defining the physical and electrical parameters of a parallel I/O bus used to connect initiators to devices. (2) a processor-independent standard protocol for system-level interfacing between a computer and intelligent devices including hard drives, floppy disks, CD-ROMs, printers, scanners, and others.
SCSI-A cable	A 50-conductor (25 twisted-pair) cable generally used for single-ended, SCSI-bus connections.
SCSI bus signal converter	Sometimes referred to as an adapter. (1) A device used to interface between the subsystem and a peripheral device unable to be mounted directly into the SBB shelf of the subsystem. (2) a device used to connect a differential SCSI bus to a single-ended SCSI bus. (3) A device used to extend the length of a differential or single-ended SCSI bus. <i>See also</i> DWZZA, DWZZB, DWZZC, and I/O module.
SCSI device	(1) A host computer adapter, a peripheral controller, or an intelligent peripheral that can be attached to the SCSI bus. (2) Any physical unit that can communicate on a SCSI bus.
SCSI device ID number	A bit-significant representation of the SCSI address referring to one of the signal lines, numbered 0 through 7 for an 8-bit bus, or 0 through 15 for a 16-bit bus. <i>See also</i> target ID number.
SCSI ID number	The representation of the SCSI address that refers to one of the signal lines numbered 0 through 15.
SCSI-P cable	A 68-conductor (34 twisted-pair) cable generally used for differential bus connections.
SCSI port	(1) Software: The channel controlling communications to and from a specific SCSI bus in the system. (2) Hardware: The name of the logical socket at the back of the system unit to which a SCSI device is connected.

serial transmission	A method transmission in which each bit of information is sent sequentially on a single channel rather than simultaneously as in parallel transmission.
signal converter	<i>See</i> SCSI bus signal converter.
single ended I/O module	A 16-bit I/O module. <i>See also</i> I/O module.
single-ended SCSI bus	An electrical connection where one wire carries the signal and another wire or shield is connected to electrical ground. Each signal logic level is determined by the voltage of a single wire in relation to ground. This is in contrast to a differential connection where the second wire carries an inverted signal.
spareset	A collection of disk drives made ready by the controller to replace failed members of a storageset.
storage array	An integrated set of storage devices.
storage array subsystem	<i>See</i> storage subsystem.
storageset	(1) A group of devices configured with RAID techniques to operate as a single container. (2) Any collection of containers, such as stripesets, mirrorsets, striped mirrorsets, and RAIDsets.
storageset expansion	Concat commands implement storageset expansion features.
storage subsystem	The controllers, storage devices, shelves, cables, and power supplies used to form a mass storage subsystem.
storage unit	The general term that refers to storagesets, single-disk units, and all other storage devices that are installed in your subsystem and accessed by the host. A storage unit can be any entity that is capable of storing data, whether it is a physical device or a group of physical devices.
StorageWorks	<p>A family of Compaq modular data storage products that allow customers to design and configure their own storage subsystems. Components include power, packaging, cabling, devices, controllers, and software. Customers can integrate devices and array controllers in StorageWorks enclosures to form storage subsystems.</p> <p>StorageWorks systems include integrated SBBs and array controllers to form storage subsystems. System-level enclosures to house the shelves and standard mounting devices for SBBs are also included.</p>

stripe	The data divided into blocks and written across two or more member disks in an array.
striped mirrorset	<i>See</i> RAID level 0+1.
stripeset	<i>See</i> RAID level 0.
stripe size	The stripe capacity as determined by $n-1$ times the chunksize, where n is the number of RAIDset members.
striping	<p>The technique used to divide data into segments, also called chunks. The segments are striped, or distributed, across members of the stripeset. This technique helps to distribute hot spots across the array of physical devices to prevent hot spots and hot disks.</p> <p>Each stripeset member receives an equal share of the I/O request load, improving performance.</p>
surviving controller	The controller in a dual-redundant configuration pair that serves its companion devices when the companion controller fails.
switch	A method that controls the flow of functions and operations in software.
synchronous	Pertaining to a method of data transmission which allows each event to operate in relation to a timing signal. <i>See also</i> asynchronous.
tape	A storage device supporting sequential access to variable sized data records.
target	(1) A SCSI device that performs an operation requested by an initiator. (2) Designates the target identification (ID) number of the device.
target ID number	The address a bus initiator uses to connect with a bus target. Each bus target is assigned a unique target address.
this controller	The controller that is serving your current CLI session through a local or remote terminal. <i>See also</i> other controller.
tape inline exerciser	(TILX) The controller diagnostic software to test the data transfer capabilities of tape drives in a way that simulates a high level of user activity.
transfer data rate	The speed at which data may be exchanged with the central processor, expressed in thousands of bytes per second.
ULP	Upper Layer Protocol.

ULP process	A function executing within a Fibre Channel node which conforms to the Upper Layer Protocol (ULP) requirements when interacting with other ULP processes.
Ultra SCSI	A Fast-20 SCSI bus. <i>See also</i> Wide Ultra SCSI.
unit	A container made accessible to a host. A unit may be created from a single disk drive or tape drive. A unit may also be created from a more complex container such as a RAIDset. The controller supports a maximum of eight units on each target. <i>See also</i> target and target ID number.
unwritten cached data	Sometimes called unflushed data. <i>See</i> dirty data.
UPS	Uninterruptible power supply. A battery-powered power supply guaranteed to provide power to an electrical device in the event of an unexpected interruption to the primary power supply. Uninterruptible power supplies are usually rated by the amount of voltage supplied and the length of time the voltage is supplied.
VHDCI	Very high-density-cable interface. A 68-pin interface. Required for Ultra-SCSI connections.
virtual terminal	A software path from an operator terminal on the host to the controller's CLI interface, sometimes called a host console. The path can be established via the host port on the controller or via the maintenance port through an intermediary host.
VTDPY	An abbreviation for Virtual Terminal Display Utility.
warm swap	A device replacement method that allows the complete system to remain online during device removal or insertion. The system bus may be halted, or quiesced, for a brief period of time during the warm-swap procedure.
Wide Ultra SCSI	Fast/20 on a Wide SCSI bus.
Worldwide name	A unique 64-bit number assigned to a subsystem by the Institute of Electrical and Electronics Engineers (IEEE) and set by Compaq manufacturing prior to shipping. This name is referred to as the node ID within the CLI.
write-back caching	A cache management method used to decrease the subsystem response time to write requests by allowing the controller to declare the write operation “complete” as soon as the data reaches its cache memory. The controller performs the slower operation of writing the data to the disk drives at a later time.

write-through caching A cache management method used to decrease the subsystem response time to a read. This method allows the controller to satisfy the request from the cache memory rather than from the disk drives.

write hole The period of time in a RAID level 1 or RAID level 5 write operation when an opportunity emerges for undetectable RAIDset data corruption. Write holes occur under conditions such as power outages, where the writing of multiple members can be abruptly interrupted. A battery backed-up cache design eliminates the write hole because data is preserved in cache and unsuccessful write operations can be retried.

write-through cache A cache management technique for retaining host write requests in read cache. When the host requests a write operation, the controller writes data directly to the storage device. This technique allows the controller to complete some read requests from the cache, greatly improving the response time to retrieve data. The operation is complete only after the data to be written is received by the target storage device.

This cache management method may update, invalidate, or delete data from the cache memory accordingly, to ensure that the cache contains the most current data.

Index

A

- accessing the CLI, SWCC 1–14, 5–21
- accessing the configuration menu
 - Agent 4–10, 4–12
- ADD CONNECTIONS
 - multiple-bus failover 1–12
- ADD UNIT
 - multiple-bus failover 1–12
- adding
 - client system entry
 - Agent 4–10, 4–12
 - subsystem entry
 - Agent 4–10, 4–12
 - virtual disks B–8
- adding a disk drive to the spareset
 - configuration options 5–23
- adding disk drives
 - configuration options 5–23
- Agent
 - accessing the configuration menu 4–10, 4–12
 - client system entry
 - adding 4–10, 4–12
 - configuration menu 4–10, 4–12
 - configuring 4–10, 4–12
 - adding a client system entry 4–10, 4–12
 - adding a subsystem entry 4–10, 4–12
 - changing password 4–10, 4–12
 - deleting a client system entry 4–10, 4–12
 - deleting a subsystem entry 4–10, 4–12
 - stopping and starting the Agent 4–10, 4–12
 - viewing subsystem entries 4–10, 4–12
 - viewing the client systems 4–10, 4–12
 - deleting a client system entry 4–10, 4–12
 - deleting a subsystem entry 4–10, 4–12
 - disabling startup 4–10, 4–12
 - enabling startup 4–10, 4–12
 - functions 4–1
 - installing 4–6, 4–8, 4–10
 - running 4–4
 - starting 4–10, 4–12
 - stopping 4–10, 4–12
 - subsystem entry
 - adding 4–10, 4–12
 - enabling startup 4–10, 4–12
 - using the configuration menu 4–10, 4–12
- array of disk drives 2–12
- assigning unit numbers 1–11
- assignment
 - unit numbers
 - fabric topology 5–20
 - unit qualifiers
 - fabric topology 5–20
- assignment of unit numbers
 - fabric topology
 - partition 5–21
 - single disk 5–21
- asynchronous event service B–8
- autospare
 - enabling

- fabric topology 5-24
- availability 2-18
- B**
- backup
 - cloning data 8-2
 - subsystem configuration 8-1
- C**
- cabling
 - controller pair 5-10
 - multiple-bus failover
 - fabric topology configuration 5-10
 - single controller 5-4
- cache modules
 - location 1-2, 1-3
 - read caching 1-7
 - write-back caching 1-7
 - write-through caching 1-7
- caching techniques
 - mirrored 1-8
 - read caching 1-7
 - read-ahead caching 1-7
 - write-back caching 1-7
 - write-through caching 1-7
- changing switches
 - configuration options 5-25, 5-26
- chunk size
 - choosing for RAIDsets and stripesets 2-26
 - controlling stripesize 2-26
 - using to increase request rate 2-26
 - using to increase write performance 2-27
- CHUNKSIZE 2-26
- CLI commands
 - installation verification 5-9, 5-15
 - specifying identifier for a unit 1-14, 5-21
 - verify host configuration 6-1
 - verify virtual disk 6-1
- CLI prompt
 - changing
 - fabric topology 5-23
- Client
 - removing B-7
 - uninstalling B-7
- client system entry
 - Agent
 - adding 4-10, 4-12
- CLONE utility
 - backup 8-2
- cloning
 - backup 8-2
- command console LUN 1-8
 - SCSI-2 mode 1-13
 - SCSI-3 mode 1-13
- Compaq Insight Manager B-8
- comparison of container types 2-12
- Configuration
 - fabric topology
 - procedure flowchart
 - illustrated 1-ξϖuu
- configuration
 - backup 8-1
 - fabric topology
 - devices 5-16
 - multiple-bus failover
 - cabling 5-10
 - multiple-bus failover using CLI 7-4
 - single controller cabling 5-3
 - restoring 2-28
 - rules 2-3
 - verify host 6-1
- configuration menu
 - Agent 4-10, 4-12
- configuration options
 - fabric topology
 - adding a disk drive to the spareset 5-23
 - adding disk drives 5-23
 - changing switches
 - device 5-26
 - displaying the current switches 5-25
 - initialize 5-26
 - RAIDset and mirrorset 5-26
 - unit 5-26
 - changing switches for a storageset or device 5-25

- changing the CLI prompt 5-23
 - deleting a storageset 5-25
 - enabling autospare 5-24
 - removing a disk drive from the spareset 5-24
- configuring
 - Agent 4-10, 4-12
 - pager notification B-8
- configuring devices
 - fabric topology 5-16
- configuring storage
 - SWCC 1-14
- connections 1-9
 - naming 1-9
- containers
 - attributes 2-11
 - comparison 2-12
 - illustrated 2-11
 - mirrorsets 2-16
 - planning storage 2-11
 - stripesets 2-15
- controller
 - verification of installation 5-15
- controller verification
 - installation 5-9, 5-15
- controllers
 - cabling 5-4, 5-10
 - location 1-2, 1-3
 - node IDs 1-18
 - verification of installation 5-9, 5-15
 - worldwide names 1-18
- creating
 - storageset and device profiles 2-12

D

- deleting a client system entry
 - Agent 4-10, 4-12
- deleting a subsystem entry
 - Agent 4-10, 4-12
- device switches
 - changing
 - fabric topology 5-26

- devices
 - changing switches
 - fabric topology 5-25
 - configuration
 - fabric topology 5-16
 - creating a profile 2-12
 - disabling Agent startup 4-10, 4-12
 - disabling startup
 - Agent 4-10, 4-12
 - disk drives
 - adding
 - fabric topology 5-23
 - adding to the spareset
 - fabric topology 5-23
 - array 2-12
 - corresponding storagesets 2-29
 - dividing 2-22
 - removing from the spareset
 - fabric topology 5-24
 - displaying the current switches
 - fabric topology 5-25
 - dividing storagesets 2-22

E

- enabling
 - switches 2-23
- enabling Agent startup 4-10, 4-12
- enabling startup
 - Agent 4-10, 4-12
- erasing metadata 2-28
- establishing a local connection 5-2

F

- Fabric topology
 - procedure flowchart
 - illustrated 1-ξϖuu
- fabric topology
 - configuration
 - single controller cabling 5-3
- failover 1-5
 - multiple-bus 1-5
- First enclosure of multiple-enclosure subsystem

storage map template 1 A-3, A-6, A-7, A-9,
A-11, A-12, A-14

functions
Agent 4-1

G

geometry
initialize switches 2-28

H

Host access
restricting in multiple-bus failover mode
disabling access paths 1-16

host access
restricting by offsets
multiple-bus failover 1-17
restricting in multiple-bus failover mode 1-15

host adapter
installation 3-5
preparation 3-5

host connections 1-9
naming 1-9

I

initialize switches
changing
fabric topology 5-26
CHUNKSIZE 2-26
geometry 2-28
NOSAVE_CONFIGURATION 2-28
SAVE_CONFIGURATION 2-28

installation
controller verification 5-9, 5-15
host adapter 3-5
invalid network port assignments B-3
there is no disk in the drive message B-4

installation verification
CLI commands 5-9, 5-15

installing
Agent 4-6, 4-8, 4-10

integrating SWCC B-8

invalid network port assignments B-3

J

JBOD 2-12

L

LOCATE
find devices 2-38

location
cache module 1-2, 1-3
controller 1-2, 1-3

LUN IDs
general description 1-20

M

maintenance port connection
establishing a local connection 5-2
illustrated 5-2

mapping storagesets 2-29

messages
there is no disk in the drive B-4

mirrored caching
enabling 1-8
illustrated 1-8

mirrorset switches
changing
fabric topology 5-26

mirrorsets
planning considerations 2-16
important points 2-17
switches 2-25

moving storagesets 8-6

multiple-bus failover
restricting host access by offsets 1-17

multiple-bus failover 1-5
ADD CONNECTIONS command 1-12
ADD UNIT command 1-12
ADD UNITcommand 1-12
CLI configuration procedure
fabric topology 7-4
fabric topology
preferring units 5-22
fabric topology configuration
cabling 5-10
host connections 1-12

- restricting host access 1-15
 - disabling access paths 1-16
- SET CONNECTIONS command 1-12
- SET UNIT command 1-12

N

- network port assignments B-3
- node IDs 1-18
 - restoring 1-19
- NODE_ID
 - worldwide name 1-18
- NOSAVE_CONFIGURATION 2-28

O

- offset
 - restricting host access
 - multiple-bus failover 1-17
- online help
 - SWCC B-8
- options
 - for mirrorsets 2-25
 - for RAIDsets 2-24
 - initialize 2-26
- other controller 1-3

P

- pager notification B-8
 - configuring B-8
- partitions
 - assigning a unit number
 - fabric topology 5-21
 - defining 2-22
 - planning considerations 2-22
 - guidelines 2-23
- performance 2-18
- planning
 - overview 2-12
 - striped mirrorsets 2-21
 - stripesets 2-15
- planning considerations 2-18
- planning storage
 - containers 2-11
 - where to start 2-2

- planning storagesets
 - characteristics
 - changing switches 2-24
 - enabling switches 2-23
 - initialization switch 2-23
 - storage switch 2-23
 - unit switch 2-23
 - switches
 - initialization 2-25
 - storageset 2-24
- preferring units
 - multiple-bus failover
 - fabric topology 5-22
- profiles
 - creating 2-12
 - description 2-12
 - storageset A-1
 - example A-2

R

- RAIDset switches
 - changing
 - fabric topology 5-26
- RAIDsets
 - choosing chunk size 2-26
 - maximum membership 2-19
 - planning considerations 2-18
 - important points 2-19
 - switches 2-24
- read caching
 - enabled for all storage units 1-7
 - general description 1-7
- read requests
 - decreasing the subsystem response time with
 - read caching 1-7
- read-ahead caching 1-7
 - enabled for all disk units 1-7
- remedial kit 3-5
- removing
 - Client B-7
- removing a subsystem entry
 - Agent 4-10, 4-12

- request rate 2-26
 - requirements
 - host adapter installation 3-5
 - storage configuration 1-14
 - restricting host access
 - disabling access paths
 - multiple-bus failover 1-16
 - multiple-bus failover 1-15
 - running
 - Agent 4-4
 - S**
 - SAVE_CONFIGURATION 2-28
 - saving configuration 2-28
 - SCSI-2
 - assigning unit numbers 1-13
 - command console lun 1-13
 - SCSI-3
 - assigning unit numbers 1-13
 - command console lun 1-13
 - Second enclosure of multiple-enclosure subsystem
 - storage map template 2 A-4
 - selective storage presentation 1-15
 - SET CONNECTIONS
 - multiple-bus failover 1-12
 - SET UNIT
 - multiple-bus failover 1-12
 - setting
 - controller configuration handling 2-28
 - single disk (JBOD)
 - assigning a unit number
 - fabric topology 5-21
 - Single-enclosure subsystem
 - storage map template 1
 - A-3
 - software
 - verification 3-5
 - specifying identifier for a unit
 - CLI commands 1-14, 5-21
 - specifying LUN ID alias
 - SWCC 1-15, 5-22
 - starting
 - Agent 4-10, 4-12
 - stopping
 - Agent 4-10, 4-12
 - storage
 - creating map 2-29
 - profile
 - example A-2
 - storage map 2-29
 - Storage map template 1 A-3
 - first enclosure of multiple-enclosure subsystem A-3, A-6, A-7, A-9, A-11, A-12, A-14
 - single enclosure subsystem A-3
 - Storage map template 2 A-4
 - second enclosure of multiple-enclosure subsystem A-4
 - Storage map template 3 A-5
 - third enclosure of multiple-enclosure subsystem A-5
- storageget
 - deleting
 - fabric topology 5-25
 - fabric topology
 - changing switches 5-25
 - planning considerations 2-14
 - mirrorsets 2-16
 - partitions 2-22
 - RAIDsets 2-18
 - striped mirrorsets 2-20
 - stripesets 2-14
 - profile 2-12
 - example 2-13
 - profiles A-1
 - storageget profile 2-12
 - storageget switches
 - SET command 2-24
 - storagegets
 - creating a profile 2-12
 - moving 8-6
 - striped mirrorsets
 - planning 2-21
 - planning considerations 2-20
 - stripesets

- distributing members across buses 2-16
- planning 2-15
- planning considerations 2-14
 - important points 2-15
- subsystem
 - saving configuration 2-28
- subsystem configuration
 - backup 8-1
- subsystem entry
 - Agent
 - adding 4-10, 4-12
- SWCC 4-1
 - accessing the CLI 1-14, 5-21
 - additional information B-8
 - configuring storage 1-14
 - integrating B-8
 - online help B-8
 - specifying LUN ID alias 1-15, 5-22
- switches
 - changing 2-24
 - changing characteristics 2-23
 - CHUNKSIZE 2-26
 - enabling 2-23
 - mirrorsets 2-25
 - NOSAVE_CONFIGURATION 2-28
 - RAIDset 2-24
 - SAVE_CONFIGURATION 2-28
- switches for storage sets
 - overview 2-23

T

- templates
 - subsystem profile A-1
- terminology
 - other controller 1-3
 - this controller 1-3
- Third enclosure of multiple-enclosure subsystem
 - storage map template 3 A-5
- this controller 1-3
- tooggling startup
 - Agent 4-10, 4-12
- troubleshooting

- invalid network port assignments B-3
- there is no disk in the drive message B-4

U

- uninstalling
 - Client B-7
- unit numbers
 - assigning 1-11
 - fabric topology 5-20
 - assigning depending on SCSI version 1-13
 - assigning in fabric topology
 - partition 5-21
 - single disk 5-21
- unit qualifiers
 - assigning
 - fabric topology 5-20
- unit switches
 - changing
 - fabric topology 5-26
- units
 - LUN IDs 1-20
- using the configuration menu
 - Agent 4-10, 4-12

V

- verification
 - controller installation 5-9, 5-15
 - software 3-5
- verification of installation
 - controller 5-9, 5-15
- verify host configuration
 - CLI commands 6-1
- verify virtual disk
 - CLI commands 6-1
- virtual disks
 - adding B-8

W

- worldwide names 1-18
 - NODE_ID 1-18
 - REPORTED_PORT_ID 1-18
- restoring 1-19
- write performance 2-27

write requests

improving the subsystem response time with

write-back caching 1-7

placing data with with write-through caching

1-7

write-back caching

general description 1-7

write-through caching

general description 1-7